

Table of contents

	Page
Safety notes / Technical support	G2

Introduction	G3

Function	G4

Technical data	G6

Approvals	G14

Options	G15

Mounting	G16

Electrical installation	G19

Switching logic	G25

Settings / Maintenance	G27

Notes for use in Hazardous Locations	G28

Subject to technical change
All dimensions in mm (inches).

We assume no liability for typing errors.
Different variations than specified are possible.
Please contact our technical consultants.



Safety notes / Technical support

Notes

- Installation, maintenance and commissioning must be carried out only by qualified technical personnel.
- The product must be used only in the manner outlined in this instruction manual.

Special attention must be paid to warnings and notes as follows:



WARNING

Relates to a caution symbol on the product and means, that a failure to observe the necessary precautions can result in death, serious injury and/or considerable material damage.



WARNING

Failure to observe the necessary precautions can result in death, serious injury and/or considerable material damage.

This symbol is used, when there is no corresponding caution symbol on the product.

CAUTION

Failure to observe the necessary precautions can result in considerable material damage.

Safety symbols

In manual and on
product

Description



CAUTION: refer to accompanying documents (manual) for details.



Earth (ground) Terminal



Protective Conductor Terminal

Introduction

Applications

The ROTONIVO is an electromechanical Level limit switch and is used for level monitoring of bulk goods.

The units can be delivered with a wide range of Ex-approvals for use in Hazardous Areas.

They can be equipped for process over- and lowpressure and also for very high or low process temperatures.

Selected applications:

- **building materials industry**
lime, styrofoam, moulding sand, etc.
- **food industry**
milk powder, flour, salt, etc.
- **plastics industry**
plastics granules etc.
- **timber industry**
- **chemical industry**
- **mechanical engineering**

The ROTONIVO is normally screwed into the lateral container wall so that it is level with the filling height to be registered and monitored.

The device can also be mounted from the top of the container. In this case an extension piece is used to mount the probe level with the height to be registered.

The length of the probe can be up to 10m (394") with an extension tube or rope.

The use of a sliding sleeve for the version RN 3002 / 6002 is recommended so that the switch point can be changed easily during operation of the device.

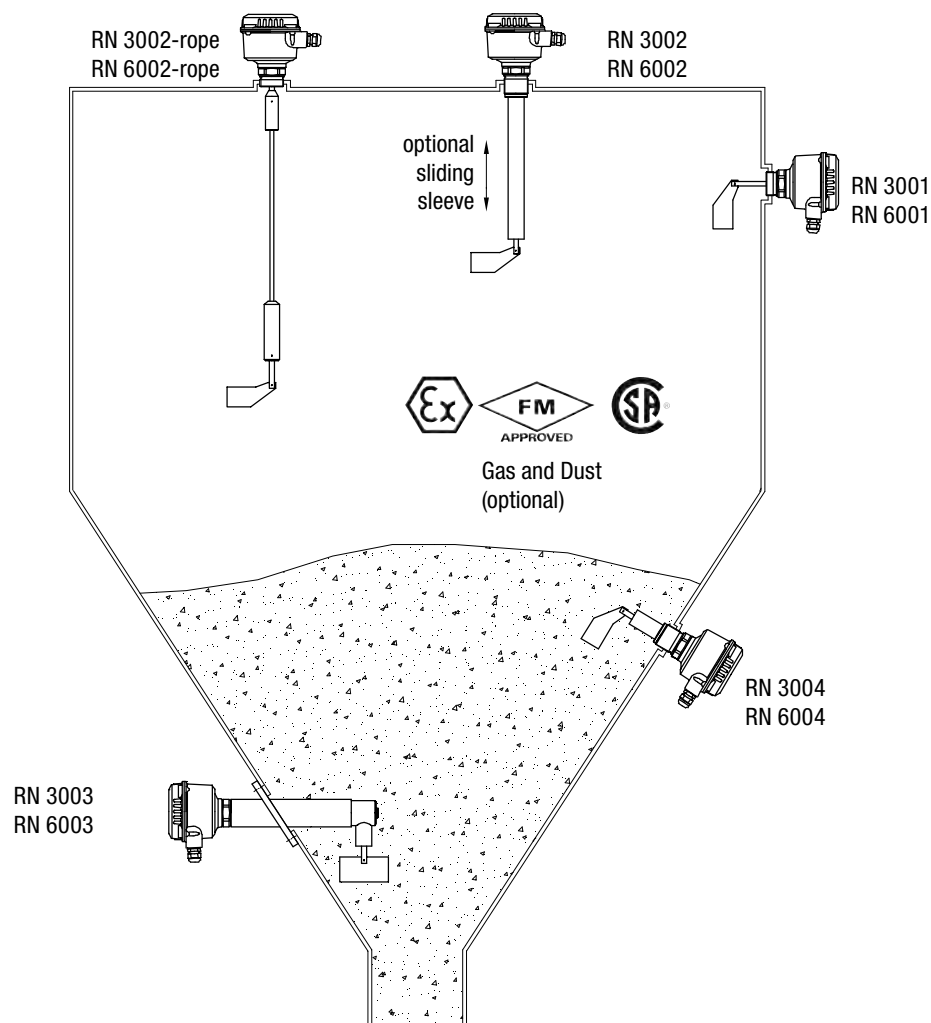

Function

A brushless synchronous motor drives a rotating measuring vane.

When the material level reaches the measuring vane, it is handicapped in its rotation. The motor is freely suspended within the housing. The caused reaction torque is used to operate a micro switch giving a signal output and to stop the motor (figure 2).

When the paddle becomes free again due to falling material level, a spring draws the motor back into his operating position, the micro switch returns to his initial position and the motor is switched on. The output signal is switched back (figure 1).

Option fail safe alarm

With the fail safe alarm it is possible to recognize a fault of the unit in time and to initiate an alarm relay. The following faults are observed:

- Motor
- Gear
- Electronic for motor power supply
- Supply voltage failure
- Defect of the connecting wires

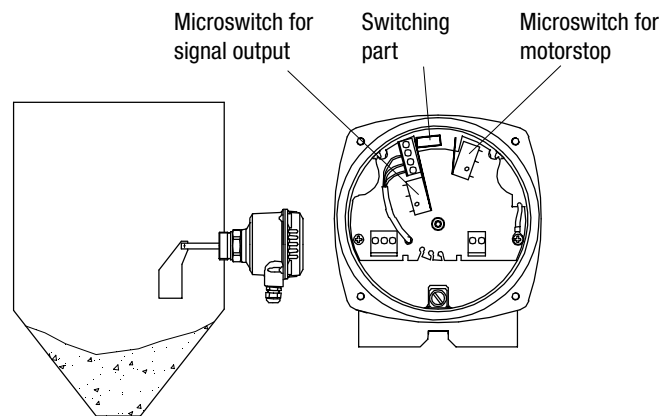

Figure 1

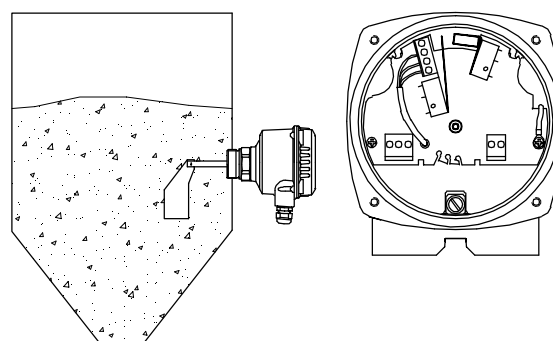
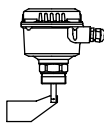
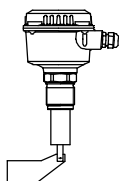
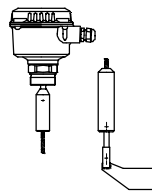
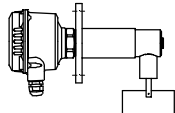
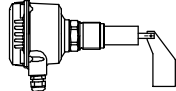

Figure 2

Function

Selection guide

	RN 3001 RN 6001	RN 3002 RN 6002	RN 3002-rope RN 6002-rope	RN 3003 RN 6003	RN 3004 RN 6004
					
Full detector	X	X	X	X	X
Demand detector	X		X*	X	X
Empty detector	X		X*	X	X
Vertical mounting	X	X	X*		X
Oblique from the top	X	X**			X
Horizontal mounting	X			X	X
Oblique from the bottom	X				X

* consider max. permitted mech. traction force

** only with option "bearing at tube end"

Shaft sealing and metal material

Application	Sealing material ⁽¹⁾			Metal material		Bearing
	NBR	FPM (Viton)	PTFE (Teflon)	Aluminium	Stainless steel 1.4301/ SS 304	Stainless steel 1.4301/ SS 304
Animal feed press			X		X	X
Synthetic granules, powders	X			X		
Salt			X		X	X
Dust filter (temp. up to 392°F)			X		X	
Dust filter (temp. up to 302°F)		X			X	
Bitumen			X		X	
Cement	X			X		
Wood chip dryer			X		X	
Pressure conveying vessel, 8bar			X		X	
Sugar	X			X		
Flour	X			X		
Carbon black	X			X		

⁽¹⁾ Used in version with process temperature and process pressure as following:

NBR: max 80°C and max. 0.8bar
 FPM (Viton): max. 150°C and max. 0.8bar
 PTFE (Teflon): max. 250°C/ 350°C and max. 0.8bar
 max. 80°C/ 150°C/ 250°C and max. 5bar/ 10bar

Technical Data

Housing versions

Series RN 3000

Standard

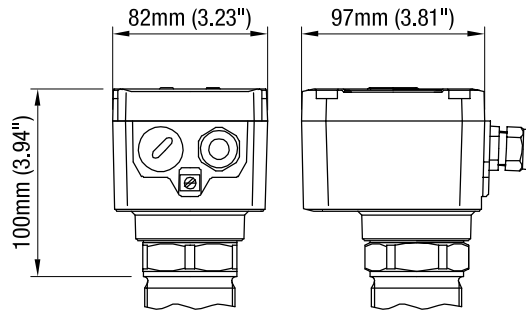

Series RN 6000

Standard

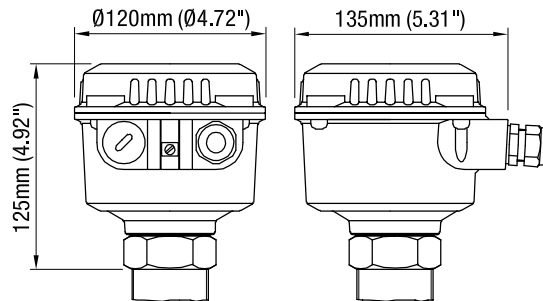

de

explosionproof with
 increased safety
 terminal box

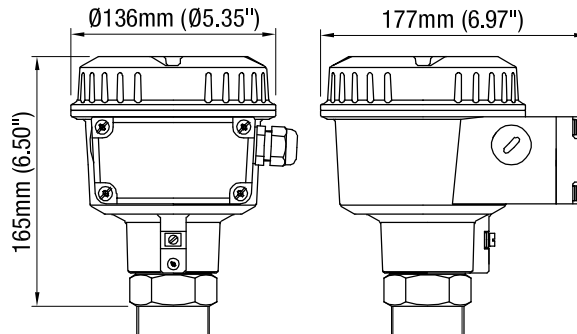

d

flameproof /
 explosionproof

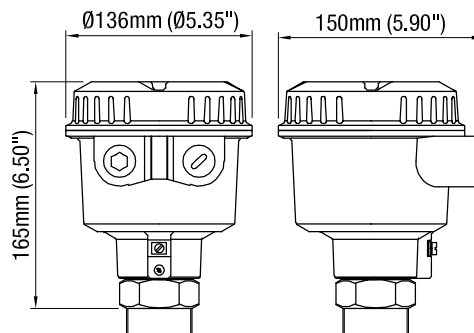

Technical Data

Extensions

RN 3001 RN 6001

Process temperature	A
150 / 250°C (302 / 482°F)	200mm (7.87")
350°C (662°F)	300mm (11.8")

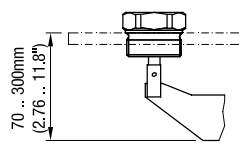

Thread / Flange

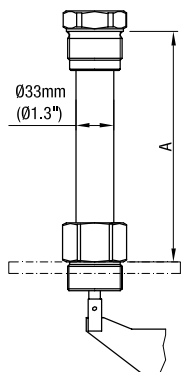

Temperature extended shaft

RN 3002 RN 6002

Process-temperature	A
150 / 250°C (302 / 482°F)	200mm (7.87")
350°C (662°F)	300mm (11.8")

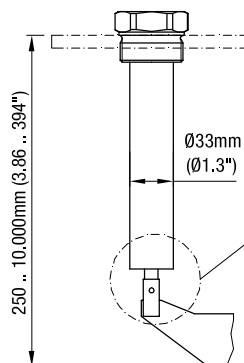

Thread / Flange

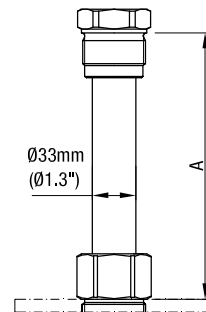

Temperature extended shaft

Without sealing and bearing at tube end (see also option pos.32)

RN 3002 - rope RN 6002 - rope

Type standard (pos.1 C)
(max. 4kN load)

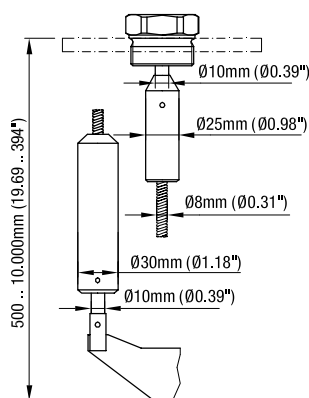

Thread / Flange

Type reinforced (pos.1 H)
(max. 28kN load)

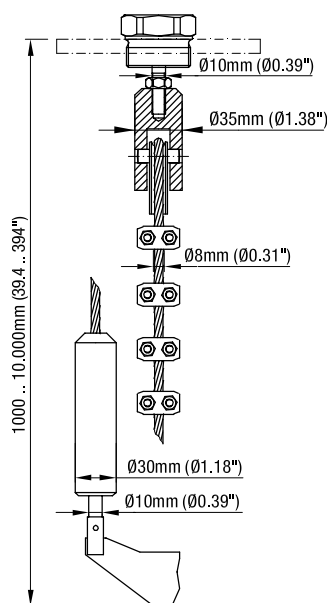

Thread / Flange

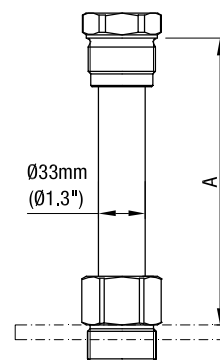

Temperature extended shaft

Process-temperature	A
150 / 250°C (302 / 482°F)	200mm (7.87")
350°C (662°F)	300mm (11.8")

Technical Data

RN 3003 RN 6003

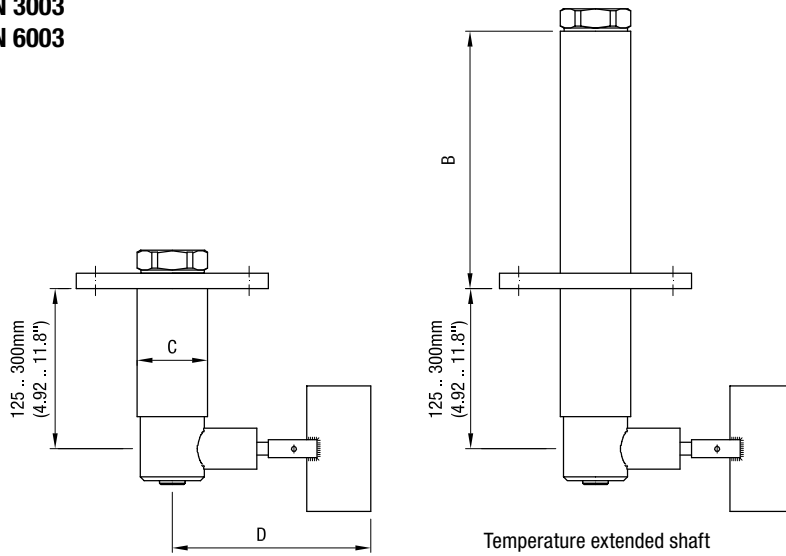

Process-temperature	B
80°C (176°F) 0.8 bar (11.6psi)	10mm (0.39")
80°C (176°F) 5/ 10bar (73/ 145psi)	75mm (2.95")
150/ 250°C (302/ 482°F) 0,8/5/10 bar (11,6/73/145psi)	210mm (8.27")

Material	C
Steel	ø55mm (2.17")
Aluminium	ø60mm (2.36")

Vane	D
50mm x ..mm (1.97" x ..")	139mm (5.47")
98mm x ..mm (3.86" x ..")	187mm (7.36")

RN 3004 RN 6004

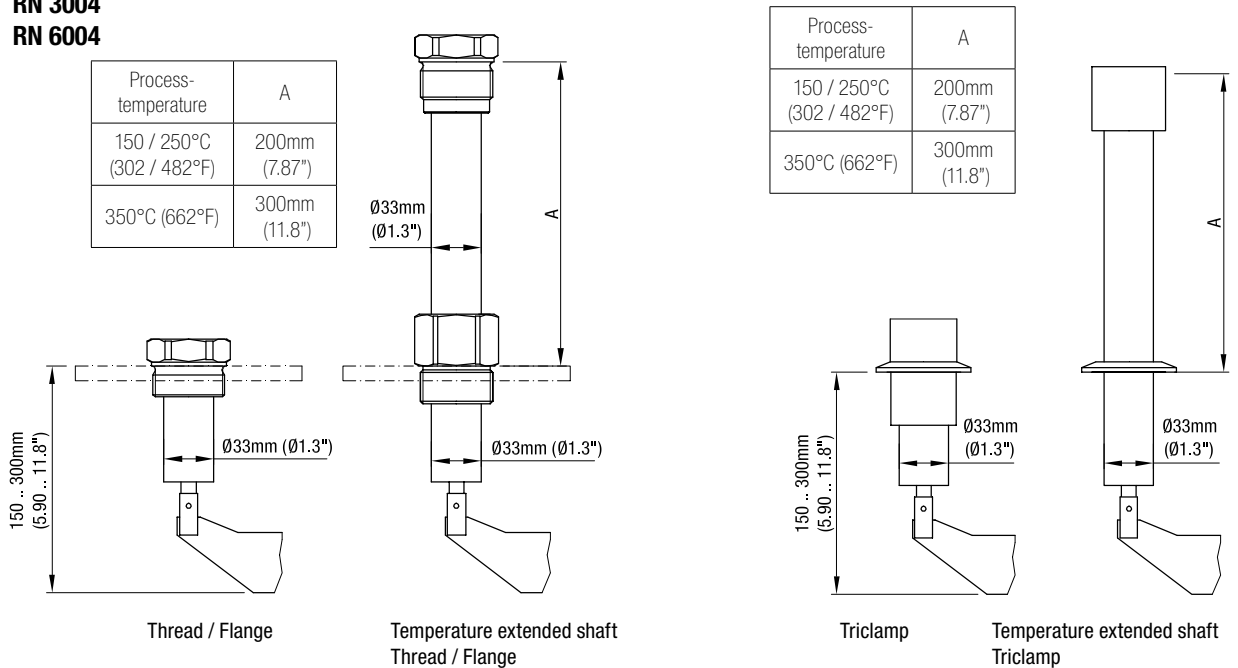

Process-temperature	A
150 / 250°C (302 / 482°F)	200mm (7.87")
350°C (662°F)	300mm (11.8")

Process-temperature	A
150 / 250°C (302 / 482°F)	200mm (7.87")
350°C (662°F)	300mm (11.8")

RN 3005

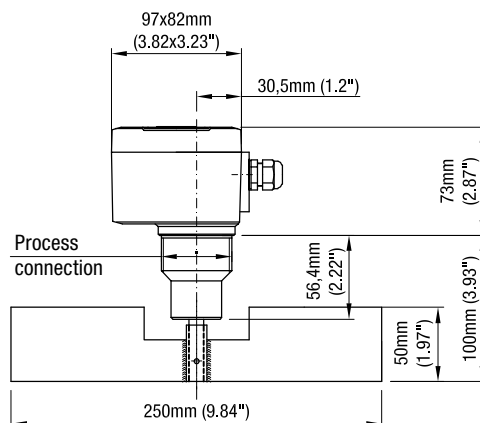

Technical Data

Measuring vanes

Code	Type	a	b
B	rectangular	50mm (1.97")	98mm (3.86")
C	rectangular	50mm (1.97")	150mm (5.90")
E	rectangular	50mm (1.97")	250mm (9.84")
F	rectangular	98mm (3.86")	98mm (3.86")
G	rectangular	98mm (3.86")	150mm (5.90")
I	rectangular	98mm (3.86")	250mm (9.84")

code B,C,E,F,G,I
 rectangular vane

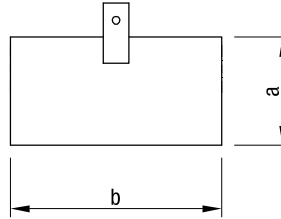

code P
 notched 40x80

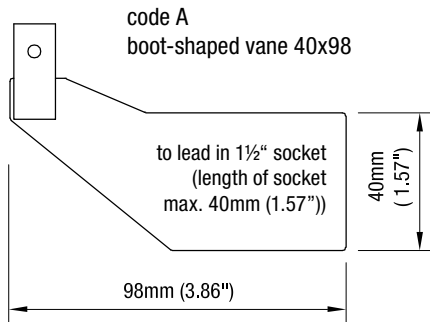
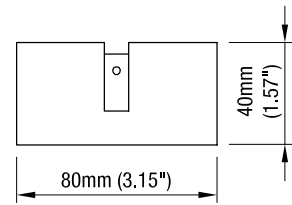

code K
 hinged vane 98x200 double sided

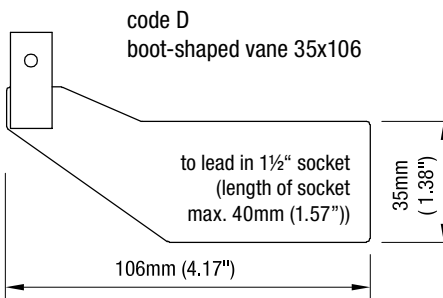
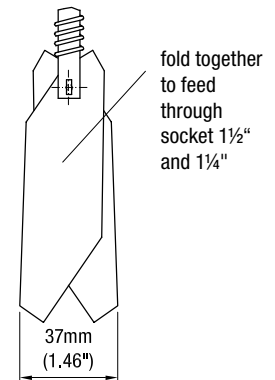
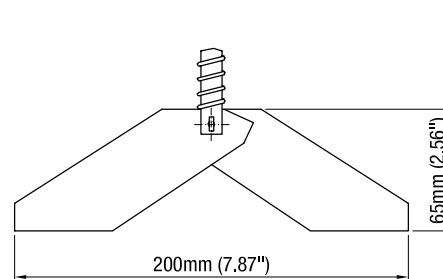

code S
 hinged vane 98x100 single sided

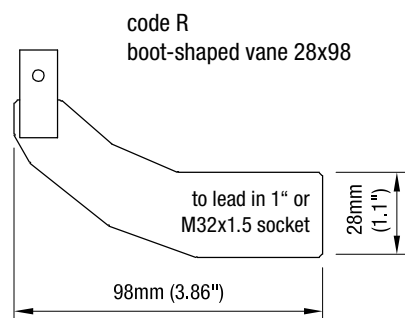
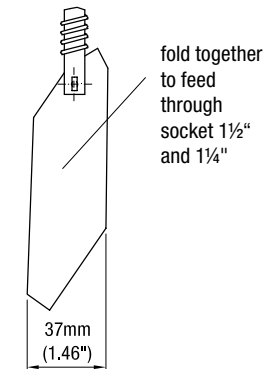
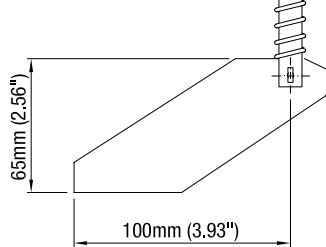

Example: insertion of the hinged vane through a long socket

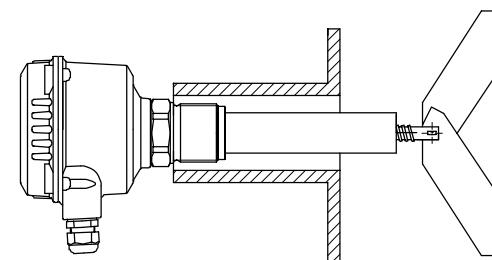
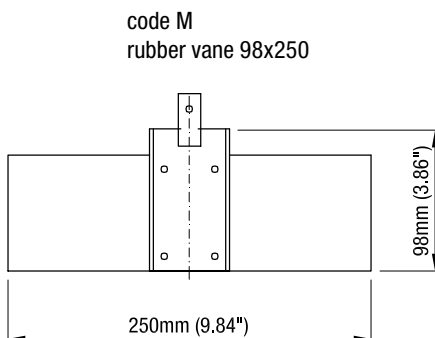
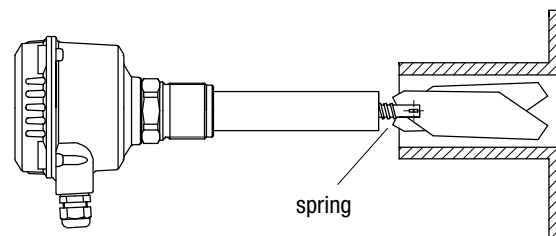

Technical Data

Electrical data

Connection terminals RN 3000 max. 1.5mm² (AWG 16)
 RN 6000 max. 4mm² (AWG 12)

Cable entry 20 x 1,5 screwed cable gland
 NPT 1/2" conduit connection
 NPT 3/4" conduit connection (only RN 6000)

Protection class I

Installation category III

Pollution degree 2

Electronics	AC version	DC version	Multivoltage version
Power supply	24V or 48V or 115V or 230V 50/60Hz All voltages ±15% (including 10% of EN 61010)	24V DC ±15% (including 10% of EN 61010)	24V DC or 115V 50/60Hz or 230V 50Hz All voltages ±15% (including 10% of EN 61010)
Installed load	max. 4VA	max. 2.5W	24V DC max. 2.5W 115V AC max. 4VA 230V AC max. 6VA
Signal output	RN 3000: Microswitch SPDT contact: RN 6000: Microswitch SPDT or DPDT contact:		max. 250V AC, 2A, 500VA (cosφ= 1) max. 300V DC, 2A, 60W max. 250V AC, 5A, non inductive max. 30V DC, 4A, non inductive
Indicating light	—	Status of signal output by built-in LED	Status of signal output by built-in LED
Isolation	Power supply to signal output: 2225 Vrms		

Electronics	AC version with fail safe alarm	DC version with fail safe alarm
Power supply	24V or 48V or 115V oder 230V 50/60Hz All voltages ±15% (including 10% of EN 61010)	24V DC ±15% (including 10% of EN 61010)
Installed load	max. 5VA	max. 2.5W
Signal output	Relay and micro switch contact: RN 3000: max. 250V AC, 2A, 500VA (cosφ = 1) max. 300V DC, 2A, 60W RN 6000: max. 250V AC, 5A, non inductive max. 30V DC, 4A, non inductive	
Indicating light	Status of signal output and alarm output by built-in LED	
Isolation	Power supply to signal and alarm output: 2225 Vrms	



Technical Data

Mechanical data

Housing	Aluminium housing, powdercoated, RAL 5010 gentian blue
Degree of protection	RN 3000: IP 66 (EN 60529) RN 6000: IP 66 (EN 60529), NEMA 4, Type 4 Types with process connection and extension in stainless steel: IP 66 (EN 60529), NEMA 4X, Type 4X (not for: RN 600* with process temperature $\geq 150^{\circ}\text{C}$ (302°F), RN 6002 with sliding sleeve, RN 6003)
Process connection	Material: aluminium or stainless steel, 1.4301 (304) and 1.4305 (303) Thread: Metric or G (DIN 228) or NPT (tapered ANSI B 1.20.1) according to selection Triclamp Flanges: according to selection
Vane shaft and measuring vane	Material: stainless steel, 1.4301 (304) and 1.4305 (303)
Tolerance length "L"	$\pm 10\text{mm}$ ($\pm 0.39\text{"}$)
Bearing	Ball bearing, dust-tight
Sealing	Radial rotary shaft sealing Material: NBR (Acrylnitril-Butadien-rubber) FPM (Viton) PTFE (Teflon) See also selection guide on page G5.
Friction clutch	Protects the gear unit against impacts of the measuring vane
Speed of measuring vane	1 rotation or 5 rotations per minute

Technical Data

Overall weight
(ca.)

RN 3000	Version			Extension	
	80°C (176°F)		150/250/350°C (302/482/662°F)		
	Aluminium *	Steel *		Aluminium	Steel *
RN 3001	1.2kg (2.6 lbs)	1.5kg (3.3 lbs)	+1.2kg (+2.6 lbs)	-	-
RN 3002	1.3kg (2.9 lbs)	1.6kg (3.5 lbs)	+1.2kg (+2.6 lbs)	+1.3kg/m (+2.9 lbs per 39.3")	+2,7kg/m (+5.9 lbs per 39.3")
RN 3002-rope	2.1kg (4.6 lbs)	2.4kg (5.3 lbs)	+1.2kg (+2.6 lbs)	-	+0,25kg/m (+0.6 lbs per 39.3")
RN 3003	3.7kg** (8.1 lbs)	6.1kg** (13.4 lbs)	+1.2kg (+2.6 lbs)	+0.4kg/100mm (+0.9 lbs per 3.93")	+0.6kg/100mm (+1.3 lbs per 3.93")
RN 3004	1.3kg (2.9 lbs)	1.6kg (3.5 lbs)	+1.2kg (+2.6 lbs)	+0.15kg/100mm (+0.3 lbs per 3.93")	+0.3kg/100mm (+0.7 lbs per 3.93")
RN 3005	1.3kg (2.9 lbs)	1.6kg (3.5 lbs)			

* Process connection

** Version with flange 150x150x12mm (5.9x5.9x0.47"), L=250mm (9.84")

All weights are without flanges (except RN 3003) and smallest measuring vane.

RN 6000	Version			Extension	
	80°C (176°F)		150/250/350°C (302/482/662°F)		
	Aluminium *	Steel *		Aluminium	Steel *
RN 6001	1.5kg (3.3 lbs)	1.8kg (4.0 lbs)	+12kg (+2.6 lbs)	-	-
RN 6002	1.6kg (3.5 lbs)	1.9kg (4.2 lbs)	+1.2kg (+2.6 lbs)	+1.3kg/m (+2.9 lbs per 39.3")	+2,7kg/m (+5.9 lbs per 39.3")
RN 6002-rope	2.4kg (5.3 lbs)	2.7kg (5.9 lbs)	+1.2kg (+2.6 lbs)	-	+0.25kg/m (+0.6 lbs per 39.3")
RN 6003	4.0kg** (8.8 lbs)	6.4kg** (14.1 lbs)	+1.2kg (+2.6 lbs)	+0.4kg/100mm (+0.9 lbs per 3.93")	+0.6kg/100mm (+1.3 lbs per 3.93")
RN 6004	1.6kg (3.5 lbs)	1.9kg (4.2 lbs)	+1.2kg (+2.6 lbs)	+0.15kg/100mm (+0.3 lbs per 3.93")	+0.3kg/100mm (+0.7 lbs per 3.93")

All mentioned weights are with Standard-housing.

By use of de-housing: +1.4kg (+3.1lbs)

d-housing: +1.0kg (+2.2lbs)

* Process connection

** Version with flange 150x150x12mm (5.9x5.9x0.47"), L=250mm (9.84")

All weights are without flanges (except RN 6003) and smallest measuring vane.

Technical Data

Operating conditions

Ambient temp. (housing) RN 3000: -20 .. +70°C (-4 .. +158°F)
 RN 6000: -25 .. +60°C (-13 .. +140°F)

Version with heating of housing (pos. 26):
 RN 3000: -40 .. +70°C..(-40 .. +158°F)
 RN 6000: -40 .. +60°C..(-40 .. +140°F)

Process temperature

-25 .. + 80°C	(-13 .. +176°F)
-25 .. +150°C*	(-13 .. +302°F)
-25 .. +250°C*	(-13 .. +482°F) (220°C (428°F) for series RN 3000 with ATEX)
-25 .. +350°C*	(-13 .. +662°F) (not for version RN 3003 / 6003, not for Ex-approvals)

Version with heating of housing (pos. 26):
 -40 .. +80°C (-40 .. +176°F)
 -40 .. +150°C* (-40 .. +176°F)
 -40 .. +250°C* (-40 .. +482°F)
 -40 .. +350°C* (-40 .. +662°F) (not for version RN 3003/ RN6003)

* with temperature extended shaft

For versions with Ex-approvals: see remarks on page G28.

Min. powder density / Sensitivity see section "Sensitivity" on page G27

Signal delay

Sensor free -> covered	ca. 1.3 sec
Sensor covered -> free	ca. 0.2 sec

Features of bulk material Hardly any limitations.

Max. permitted mechanical torque

RN 3001 / 6001:

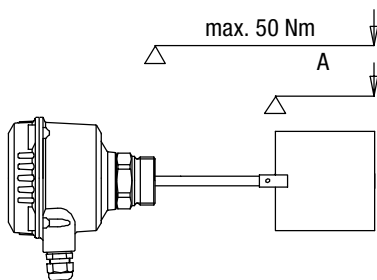

A: with reinforced measuring vane

RN 3002/ 6002
 RN 3004/ 6004:

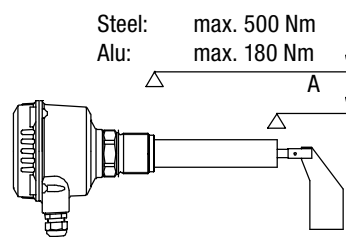

max. 50 Nm

Type RN 3003 / 6003 on request.

Protective measures in case of high loading: mounting of a protective canopy above the probe.

Max. tractive force RN 3002 / 6002-rope: 4kN (type standard) 28kN (type reinforced)

Max. process pressure -0.5 .. +0.8bar (-6.8 .. 11.6psi) or -0.8 .. +5 bar (-10.4 .. 73psi) or -0.8 .. +10 bar (-10.4 .. 145psi)
 For pressure over 0.8 bar (11.6psi) the Teflon sealing is used.
 For versions with Ex-approvals: see remarks on page G28.

Relative Humidity 0-100%, suitable for outdoor use

Altitude max. 2.000m (6.562ft)



Approvals

	RN 3000	RN 6000																																					
General Purpose * (Ordinary Locations)	• •	• •	CE EN 61010-1 (IEC/CB) FM CSA																																				
Hazardous Locations *	• •	• •	<table border="0"> <tr> <td>ATEX</td> <td>Dust explosion</td> <td></td> <td>ATEX II 1/2 D</td> </tr> <tr> <td>•</td> <td>Gas explosion</td> <td>flameproof</td> <td>ATEX II 2G EEx d IIC</td> </tr> <tr> <td>•</td> <td></td> <td>flameproof / increased safety</td> <td>ATEX II 2G EEx de IIC</td> </tr> <tr> <td>•</td> <td>FM</td> <td>Dust explosion</td> <td>Cl. II, III Div. 1 Gr. E,F,G</td> </tr> <tr> <td>•</td> <td></td> <td>Gas explosion</td> <td>flameproof</td> </tr> <tr> <td>•</td> <td></td> <td>Gas explosion</td> <td>flameproof / increased safety</td> </tr> <tr> <td>•</td> <td>CSA</td> <td>Dust explosion</td> <td>Cl. II, III Div. 1 Gr. E,F,G Ex DIP A20/21</td> </tr> <tr> <td>•</td> <td></td> <td>Gas explosion</td> <td>flameproof</td> </tr> <tr> <td>•</td> <td></td> <td>Gas explosion</td> <td>flameproof / increased safety</td> </tr> </table> <p>Detailed allocation of types and electronic modules to approvals: see pricelist.</p>	ATEX	Dust explosion		ATEX II 1/2 D	•	Gas explosion	flameproof	ATEX II 2G EEx d IIC	•		flameproof / increased safety	ATEX II 2G EEx de IIC	•	FM	Dust explosion	Cl. II, III Div. 1 Gr. E,F,G	•		Gas explosion	flameproof	•		Gas explosion	flameproof / increased safety	•	CSA	Dust explosion	Cl. II, III Div. 1 Gr. E,F,G Ex DIP A20/21	•		Gas explosion	flameproof	•		Gas explosion	flameproof / increased safety
ATEX	Dust explosion		ATEX II 1/2 D																																				
•	Gas explosion	flameproof	ATEX II 2G EEx d IIC																																				
•		flameproof / increased safety	ATEX II 2G EEx de IIC																																				
•	FM	Dust explosion	Cl. II, III Div. 1 Gr. E,F,G																																				
•		Gas explosion	flameproof																																				
•		Gas explosion	flameproof / increased safety																																				
•	CSA	Dust explosion	Cl. II, III Div. 1 Gr. E,F,G Ex DIP A20/21																																				
•		Gas explosion	flameproof																																				
•		Gas explosion	flameproof / increased safety																																				
EMC	• •		EN 61326 -A1																																				
Pressure Equipment Directive (97/23/EC)			<p>The units are not subject to this directive, because they are classified as „pressure-keeping equipment“ and do not have a pressurized housing (see Art.1, Abs. 2.1.4). The units are designed and manufactured in accordance to the Pressure Equipment Directive.</p> <p> The unit is NOT intended for use as a "equipment part with safety function" (Art.1, Abs. 2.1.3). If the units should be used as "equipment part with safety function", please contact the manufacturer.</p>																																				

* Depending on selected version in pricelist.

Options

Weather protection cover

When the measuring device is used outdoors, the use of the weather-protection-cover is recommended. It protects the device from all atmospheric influences such as:

- rain water
- condensation water
- excessively high temperatures due to insolation
- excessively low temperatures in winter

Material: PE, weather and temperature stable

Not available for housing version d and de.



For use in Hazardous Locations: only permitted for Category 3 (zone 2 and 22) or Division 2.

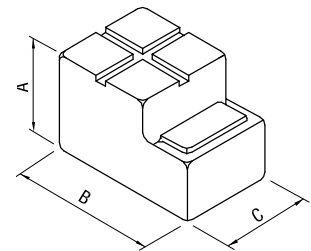

	RN 3000	RN 6000
A	100mm (3.94")	130mm (5.12")
B	160mm (6.30")	200mm (7.87")
C	90mm (3.54")	125mm (4.92")

Sliding sleeve

RN 3002 / 6002 Process connection and material as chosen

Version with selection code pos. 30:
 Only for applications without process pressure.
 Not applicable for Ex-approvals.

Version with selection code pos. 31:
 For applications with process pressure.
 Sealing material to the extension tube: viton.

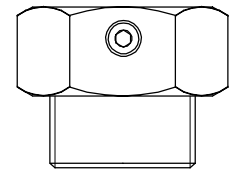

Mounting set

Screws and washers for fixing the unit on a flange.

Glas window in lid (RN 6000)

To see the indicating light on the electronic module from outside.

Not available for housing version d and de.

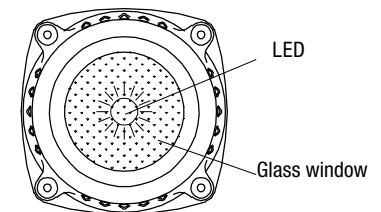

Bulb in cable gland

Bright indicating light seen from outside.

Not available for use in Hazardous Locations.

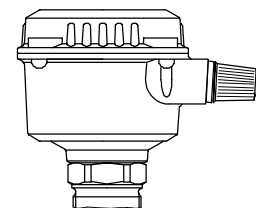

Plug 4-pole (incl. PE)

Used instead of cable gland.

Not available for use in Hazardous Locations and FM / CSA general purpose.

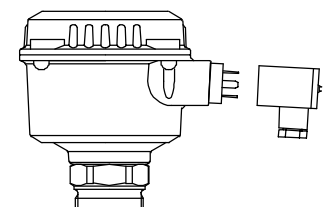

Mounting

General Safety Instructions

Process pressure	! Improper installation may result in loss of process pressure.
Chemical resistance against the medium	! Materials of construction are chosen based on their chemical compatibility (or inertness) for general purposes. For exposure to specific environments, check with chemical compatibility charts before installing.
Mechanical load	! The torque at the fastening spot must not exceed the specified ratings. See page G12 for details.
Mounting location	Keep away from incoming material and from silo walls. The installation has to be carried out, that the sensor elements cannot hit the wall of the silo. The flow of the medium and fixtures in the container must be considered. This is especially important for extension length of more than 3000mm (118")
Sliding sleeve	Tighten both straining screws M8 with 20 Nm to obtain resistance against pressure
Flange mounting	A plastic seal must be used to tighten the flange.

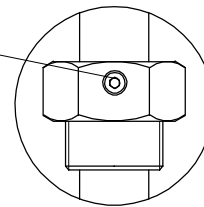

! Additional Safety Instructions for Hazardous Locations

Installation regulations	For devices to be used in Hazardous Locations the respective valid installation regulations must be observed. ATEX: The requirements of EN 50281-1-2 (e.g. regarding dust deposits and temperatures) must be observed
Sparks	The installation has to be done in a way, that mechanical friction or impact does not cause sparks between the aluminium enclosure and steel.

Mounting instructions

Rotatable housing

The housing can be rotated against the threaded connection after mounting.

RN 6000: For the d- and de- housing:
Fixing screw must be unfastened to enable rotation. Fix the screw again, when the housing has the right position.

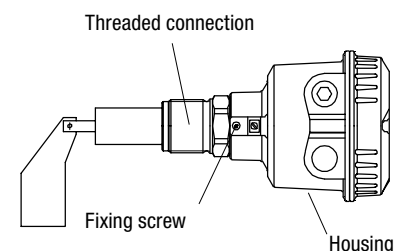

Direction of the cable glands	When the unit is mounted from the side, ensure, that the cable glands face downwards and are closed to avoid water penetration into the housing.
Sealing	Seal the process connection thread with Teflon tape against process pressure.

Mounting

RN 3001 RN 6001

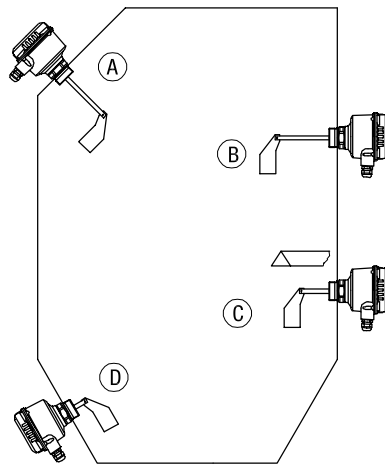

- A Full detector vertical and oblique from the top
max. „L“ = 600 mm (23.62”)
- B Full detector horizontal
max. „L“ = 300 mm (11.8”)
- C Demand or empty detector horizontal
max. „L“ = 150 mm (5.9”)
Protective angle recommended depending on load.
- D Empty detector oblique from the bottom
max. „L“ = 150 mm (5.9”)
Protective angle recommended depending on load.

Horizontal mounting: Boot shaped vane recommended (min. mech. load, for the vane aligns to the movement of the material).

RN 3002 RN 6002

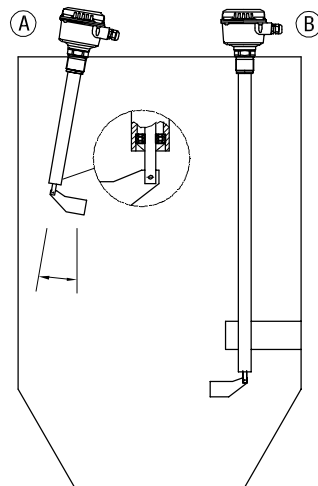

- A Full detector vertical from the top
max. „L“ = 3.000 mm (118”)

Remark:
 Deviation upto max. 10° from vertical installation with option
 „Bearing at tube end“ possible.

- B Full detector vertical from the top
max. „L“ = 10.000 mm (394”)

Support from side recommended.

RN 3002-Rope RN 6002-Rope

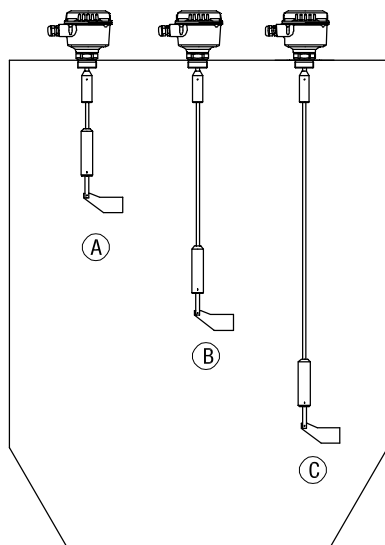

- A Full detector vertical
- B Demand detector vertical
- C Empty detector vertical

max. „L“ = 10.000 mm (394”)
 Observe max. tractive force.

Mounting

**RN 3003
 RN 6003**

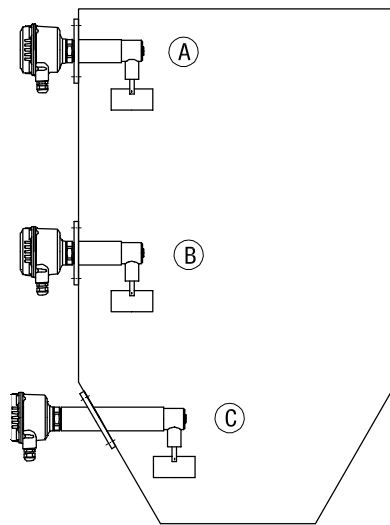

- A Full detector horizontal
- B Demand detector horizontal
- C Empty detector horizontal

Protective angle recommended depending on load.

**RN 3004
 RN 6004**

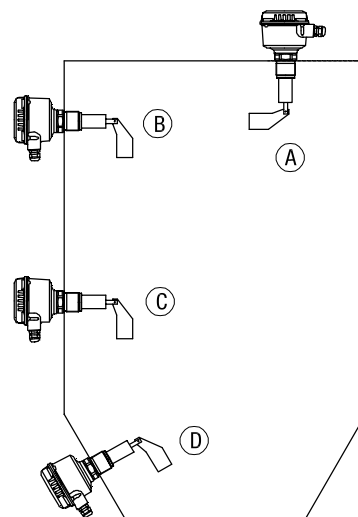

- A Full detector vertical and oblique from the top
- B Full detector horizontal
- C Demand or empty detector horizontal
 Protective angle recommended depending on load.
- D Empty detector oblique from the bottom
 Protective angle recommended depending on load.

Horizontal mounting: Boot shaped vane recommended (min. mech. load, for the vane aligns to the movement of the material).

Electrical installation

General Safety Instructions

Handling	 In the case of improper handling or handling malpractice, the electric safety of the device cannot be guaranteed.
Installation regulations	The local regulations or VDE 0100 (Regulations of German Electrotechnical Engineers) must be observed.
Fuse	Use a fuse as stated in the connection diagrams (see pages G21 and G23).
RCCB protection	In the case of a fault, the supply voltage must be automatically switched off by a RCCB protection switch to protect against indirect contact with dangerous voltages.
Power supply switch	A voltage disconnection switch must be provided near the device.
Wiring diagram	The electrical connections are made in accordance with the wiring diagram.
Supply voltage	Compare the supply voltage applied with the specifications given on the electronic module and name plate before switching the device on.
Cable gland	Make sure that the screwed cable gland safely seals the cable and that it is tight (danger of water intrusion). Cable glands that are not used have to be sealed with a blanking element.
Conduit system	In case of using a conduit system (with NPT thread) instead of a cable gland the regulations of the country, where the unit is installed, must be observed. The conduit must have a tapered thread either NPT1/2" or NPT3/4" in accordance with the unit and ANSI B 1.20.1. Not used inlets must be closed tight with a metal blanking element.
Field wiring cables	All field wirings must have insulation suitable for at least 250V AC. The temperature rating must be at least 90°C (194°F).
Microswitch protection	Provide protection for microswitch contacts to protect the device against inductive load surges.
Protection against static charging	The housing of the unit must be grounded to avoid static charging of the unit. This is particularly important for applications with pneumatic conveying and non-metallic containers.

Additional Safety Instructions for Hazardous Locations

Extenal equipotential bonding terminal

RN 3000

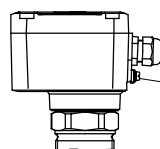

Connect to equipotential bonding of the plant

RN 6000

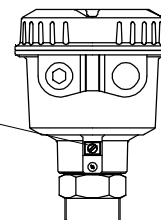

Field wiring

A strain relief must be provided for the field wiring cables, when the device is installed with the factory provided cable glands.

Electrical installation

Cable glands for ATEX Dust and Gas Hazardous Locations

General requirements:

The used entry devices and blanking elements must have an adequate type approval and a temperature range of at least -40°C (-40°F) to $+80^{\circ}\text{C}$ (176°F). In addition they shall be suitable for the conditions and correctly installed. Where applicable the provided original parts of the manufacturer must be used.

RN 6000:

Flameproof enclosure "d":

The cable entry devices of a flameproof enclosure "d" shall be of certified flameproof types of EEx "d" IIC, suitable for the conditions and correctly installed. Not used entries have to be closed with adequate blanking elements of certified flameproof types of EEx "d" IIC.

Increased Safety "e" ("de") and Dust Hazardous enclosures:

For increased safety "e" and dust hazardous applications, the cable entry devices and blanking elements are provided from the manufacturer and shall be in a certified type of explosion protection increased safety EEx "e" IIC or flameproof enclosure EEx "d" IIC. Not used entries have to be closed with adequate blanking elements of a certified increased safety type EEx "e" IIC or flameproof type EEx "d" IIC.

Conduit system for ATEX Dust and Gas Hazardous Locations

General requirements:

In addition the regulations of the country must be observed. The used flameproof seals and blanking elements must have an adequate type approval and a temperature range of at least -40°C (-40°F) to $+80^{\circ}\text{C}$ (176°F). In addition they shall be suitable for the conditions and correctly installed. Where applicable the provided original parts of the manufacturer must be used.

RN 6000:

Installation of a flameproof enclosure "d" with a conduit system:

In a conduit system single electric conductors are installed in a certified pipe system. This pipe system is in a flameproof construction as well. The flameproof enclosure "d" and the pipe system needs to be sealed from each other by a certified flameproof seal of a type EEx "d" IIC. This flameproof seals shall be installed directly in or at the conduit entries of the flameproof enclosure "d". Not used entries have to be closed with adequate blanking elements of a certified flameproof type EEx "d" IIC.

Conduit system for FM and CSA Dust and Gas Hazardous Locations

General requirements:

In addition the regulations of the country must be observed. The used flameproof seals and blanking elements must have an adequate type approval and a temperature range of at least -40°C (-40°F) to $+80^{\circ}\text{C}$ (176°F). In addition they shall be suitable for the conditions and correctly installed. Where applicable the provided original parts of the manufacturer must be used.

RN 6000:

Installation of a flameproof enclosure "d" with a conduit system:

In a conduit system single electric conductors are installed in a certified pipe system. This pipe system is in a flameproof construction as well. The flameproof enclosure "d" and the pipe system needs to be sealed from each other by a certified flameproof seal. Conduit entries of a flameproof enclosure "d" shall have installed the flameproof seal within 18 inches from the enclosure wall. Not used entries have to be closed with adequate blanking elements of a certified flameproof type AEx Cl.1 Div.1 A.

Commissioning

Commissioning only with closed lid.

Opening the lid



Units with Dust Explosion approval:
Before opening the lid take care, that no dust deposits or whirlings are present.
Do not remove the lid (cover) while circuits are alive.

RN 6000:



Units with flameproof GasExplosion approval (d-housing):
To prevent ignition of hazardous atmospheres, do not remove the lid (cover) while circuits are alive.

Electrical installation

Connection

RN 3000: Standard housing

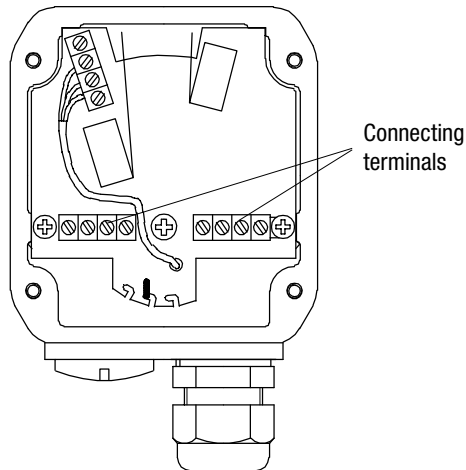

RN 6000: Standard and d-housing

Connection is done directly on the PCB

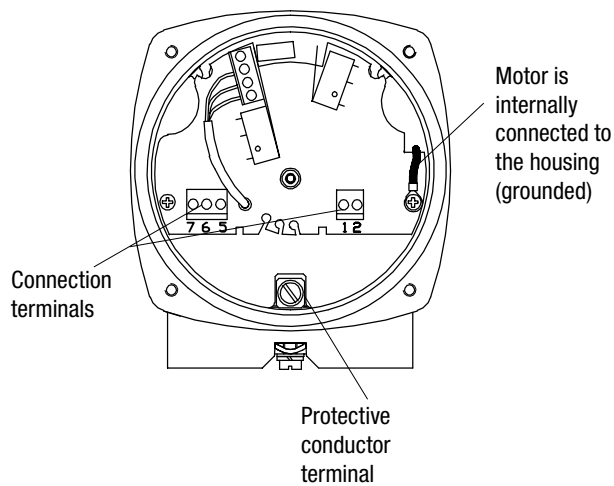

de-housing

Connection is done on the terminals inside the increased safety area.

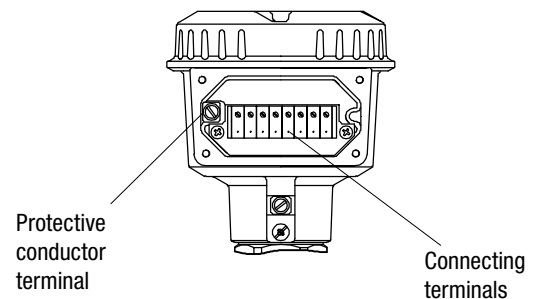

Electrical installation

AC version

DC version

without fail safe alarm

RN 3000:

Power supply AC version:

24V or 48V or 115V or 230V 50/60Hz
 max. 4VA

Supply voltage as selected (see type plate).
 All voltages $\pm 15\%$ (including 10% of EN 61010)
 Fuse on power supply: max 10A

Power supply DC version:

24V DC max. 2.5W

Voltage $\pm 15\%$ (including 10% of EN 61010)
 Fuse on power supply: not necessary

Signal output:

Micro switch SPDT contact:
 max. 2*50V AC, 2A, 500VA ($\cos\phi = 1$)
 max. 300V DC, 2A, 60W

Fuse on signal output: max 10A

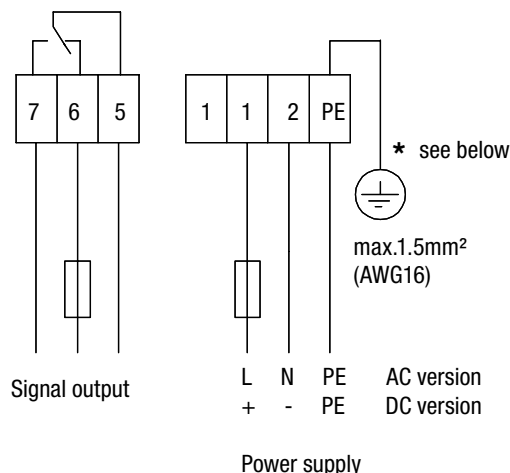

RN 6000:

Power supply AC version:

24V or 48V or 115V or 230V 50/60Hz
 max. 4VA

Supply voltage as selected (see name plate).
 All voltages $\pm 15\%$ (including 10% of EN 61010)
 Fuse on power supply: max 10A

Power supply DC version:

24V DC max. 2.5W

Voltage $\pm 15\%$ (including 10% of EN 61010)
 Fuse on power supply: not necessary

Signal output:

Micro switch SPDT or DPDT contact:
 max. 250V AC, 5A, non inductive;
 max. 30V DC, 4A, non inductive

Fuse on signal output: max 10A

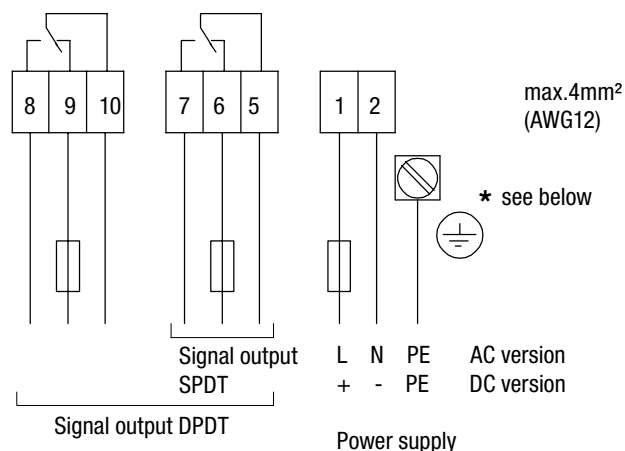

* **Protection against static charging:**
 The PE terminal of the unit must be grounded to avoid static charging of the unit.
 This is particularly important for applications with pneumatic conveying.

Electrical installation

Multivoltage
 without fail safe
 alarm

RN 3000:

Power supply:

24V DC	max. 2.5W	or
115V 50/60Hz	max. 4VA	or
230V 50Hz	max. 6VA	

Set the voltage-selector on the PCB to the desired voltage.

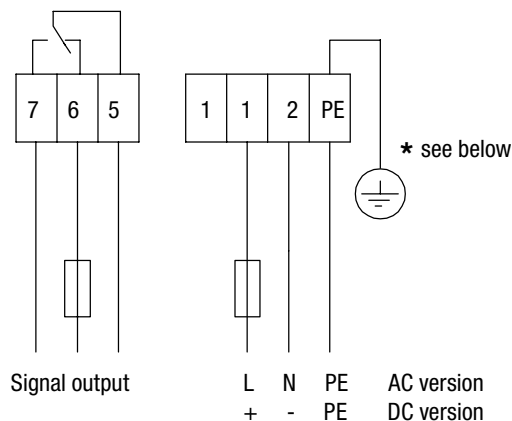
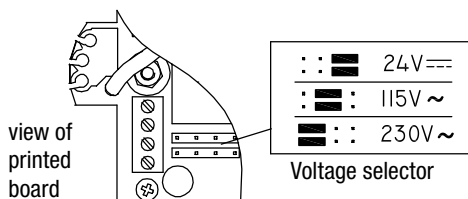

Signal output:

Micro switch SPDT contact:
 max. 250V AC, 2A, 500VA (cosφ = 1)
 max. 300V DC, 2A, 60W

Fuse on signal output: max 10A

RN 6000:

Power supply:

24V DC	max. 2.5W	or
115V 50/60Hz	max. 4VA	or
230V 50Hz	max. 6VA	

Set the voltage-selector on the printed board to the desired voltage.

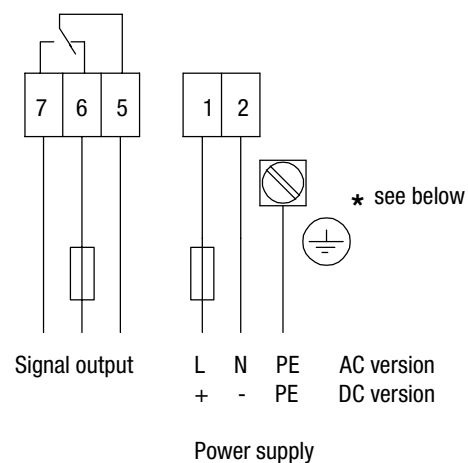
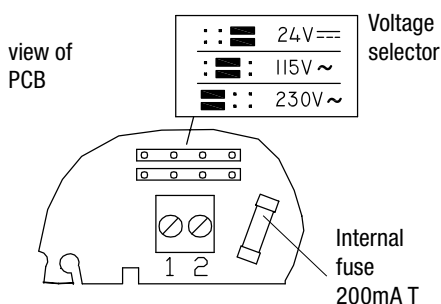

Signal output:

Micro switch SPDT contact:
 max. 250V AC, 5A, non inductive;
 max. 30V DC, 4A, non inductive;

Fuse on signal output: max 10A

*** Protection against static charging:**
 The PE terminal of the unit must be grounded to avoid static charging of the unit.
 This is particularly important for applications with pneumatic conveying.

Electrical installation

AC version DC version

with fail safe alarm

RN 3000:

Power supply AC version:

24V or 48V or 115V or 230V 50/60Hz
 max. 5VA

Supply voltage as selected (see name plate).
 All voltages $\pm 15\%$ (including 10% of EN 61010)

Power supply DC version:

24V DC max. 2,5W
 voltage $\pm 15\%$ (including 10% of EN 61010)

Signal output: Micro switch on terminal 5-6-7
Alarm output: Relay on terminal 8

Relay and Micro switch SPDT contact:
 max. 250V AC, 2A, 500VA ($\cos\phi = 1$)
 max. 300V DC, 2A, 60W

Fuse on signal output: max 10A

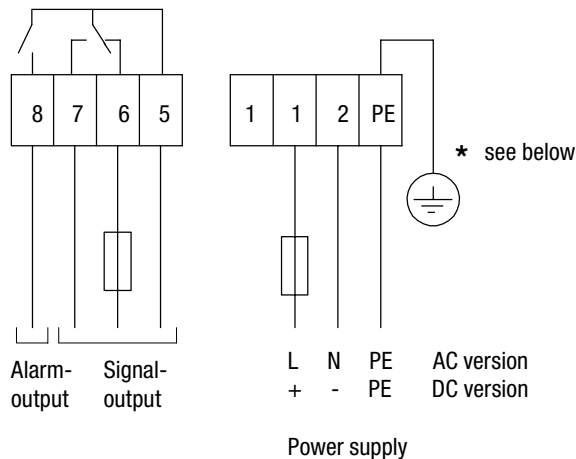

RN 6000:

Power supply AC version:

24V or 48V or 115V or 230V 50/60Hz
 max. 5VA

Supply voltage as selected (see name plate).
 All voltages $\pm 15\%$ (including 10% of EN 61010)

Power supply DC version:

24V DC max. 2.5W
 voltage $\pm 15\%$ (including 10% of EN 61010)

Signal output: Micro switch on terminal 5-6-7
Alarm output: Relay on terminal 8

Relay and Micro switch SPDT contact:
 max. 250V AC, 5A, non inductive;
 max. 30V DC, 4A, non inductive;

Fuse on signal output: max 10A

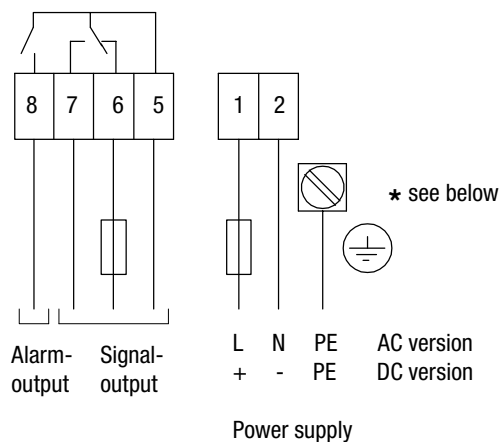

- * **Protection against static charging:**
 The PE terminal of the unit must be grounded to avoid static charging of the unit.
 This is particularly important for applications with pneumatic conveying.

Switching logic

RN 3000

LEDs on PCBs

DC and Multivoltage versions

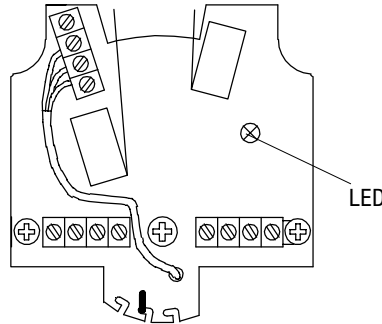

Signal output

Versions without fail safe alarm

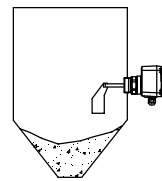

DC



Multivoltage

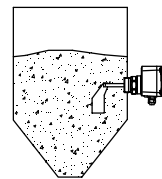

Alarm output

Versions with fail safe alarm

No fault

LED off

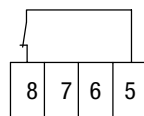

Fault

LED red

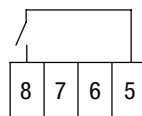

Connection example:

Full detector with maximum safety:
 The output signal opens in case of:

- full signal or
- failure of mains voltage or
- defect of the connection wires or
- defect unit

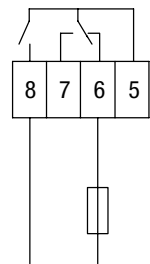

Signal output

Switching and timing behaviour:

If the vane is not covered, the rotating vane shaft will send pulses at 20 sec. intervals. In case of fault, the pulses are missed. After 30 sec. the alarm relay will open.

Switching logic

RN 6000

LEDs on PCBs

Version without fail safe alarm (DC and Multivoltage)

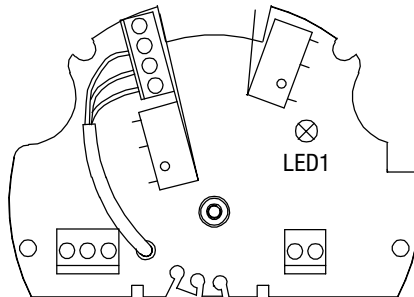

Version with fail safe alarm (AC and DC)

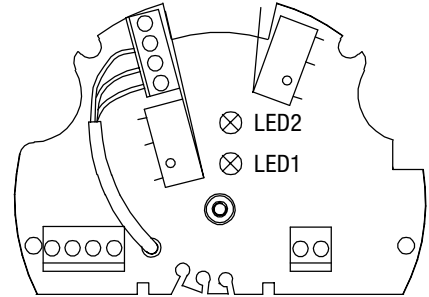

Signal output All versions

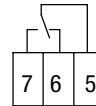
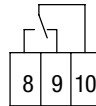
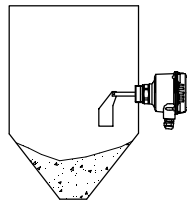

LED1

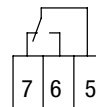
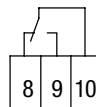
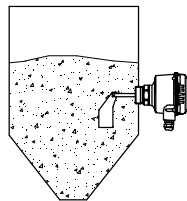

Alarm output Versions with fail safe alarm

No fault

LED 2
off

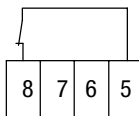

Fault

LED 2
red

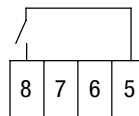

Connection example:

Full detector with maximum safety:

The output signal opens in case of:

- full signal or
- failure of mains voltage or
- defect of the connection wires or
- defect unit

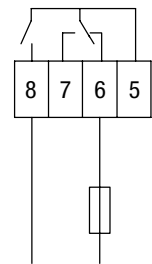

Signal output

Switching and timing behaviour:

If the vane is not covered, the rotating vane shaft will send pulses at 20 sec. intervals. In case of fault, the pulses are missed. After 30 sec. the alarm relay will open.

Settings: Sensitivity / Maintenance

Adjustment of the spring

The spring is adjustable in 3 positions. It should be changed only if necessary.

- „Fine“: for light material
- „Medium“: suitable for nearly every material
- „Coarse“: for very sticky material

Factory setting is „medium“.

The spring can be changed via small pliers.

RN 3000

RN 6000

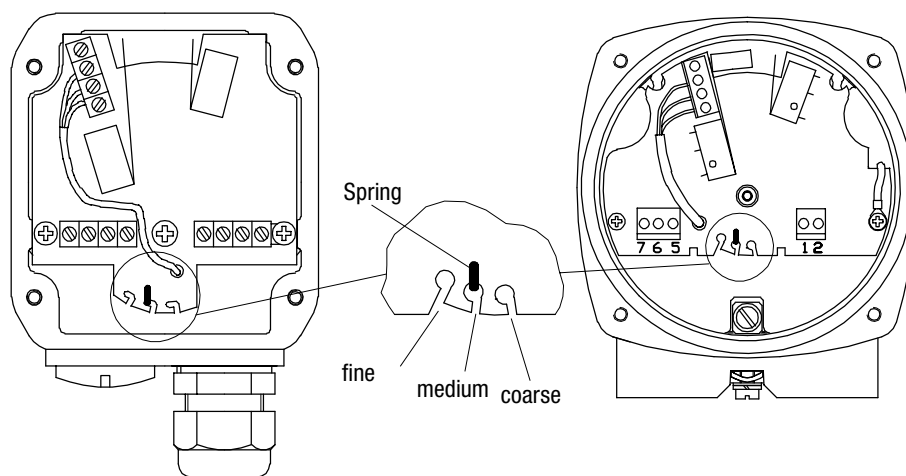

Sensitivity

The table shows approximate values for the minimum densities, at which a normal function should be possible.

Vane	*Minimum density in g/l = kg/m ³ (lb/ft ³) (without guarantee)			
	Vane completely covered with bulk material		Bulk material covers the vane upto 100mm (3.93")	
	Spring adjustment		Spring adjustment	
	fine	medium (factory setting)	fine	medium (factory setting)
Boot shaped vane 40x98	200 (12)	300 (18)	100 (60)	150 (9)
Boot shaped vane 35x106	200 (12)	300 (18)	100 (60)	150 (9)
Boot shaped vane 28x98	300 (18)	500 (30)	150 (9)	200 (12)
Vane 50x98	300 (18)	500 (30)	150 (9)	250 (15)
Vane 50x150	80 (4.8)	120 (7.2)	40 (2.4)	60 (3.6)
Vane 50x250	30 (1.8)	50 (3)	15 (0.9)	25 (1.5)
Vane 98x98	100 (60)	150 (9)	50 (3)	75 (4.5)
Vane 98x150	30 (1.8)	50 (3)	15 (0.9)	25 (15)
Vane 98x250	20 (1.2)	30 (1.8)	15 (0.9)	15 (0.9)
Hinged vane 98x200	70 (4.2)	100 (60)	35 (2.16)	50 (3)

The above mentioned data is a guideline and is for loose, non compacted material. During the filling the bulk density can change (e. g. for fluidised material).

*For versions with option 26 (heating of housing) the above mentioned data must be multiplied by 1.5.

Maintenance

Generally the device requires no maintenance.



Notes for use in Hazardous Locations

ATEX Zone classification

	Category	useable in zone
Dust applications	1 D	20, 21, 22
	2 D	21, 22
	3 D *	22
Gas applications	1 G	0, 1, 2
	2 G	1, 2
	3 G	2

*) in case of conductive dust additional requirements for the installation are necessary.

General Notes

Marking

Devices with EX approval are marked on name plate.

Process pressure for ATEX



The device construction allows process over-pressure upto 0.8/5/10 bars (11.6/73/145psi) (see name plate). These pressures are allowed for test purposes. The definition of the ATEX is only valid for a container-over-pressure between -0.2..+0.1 bars (-2.9..+1.45psi). For higher or lower pressures the approval is not valid.

Process and ambient temperature

The permitted temperature ranges are marked on the name plate.

Permitted zones (categories) for mounting in partition wall

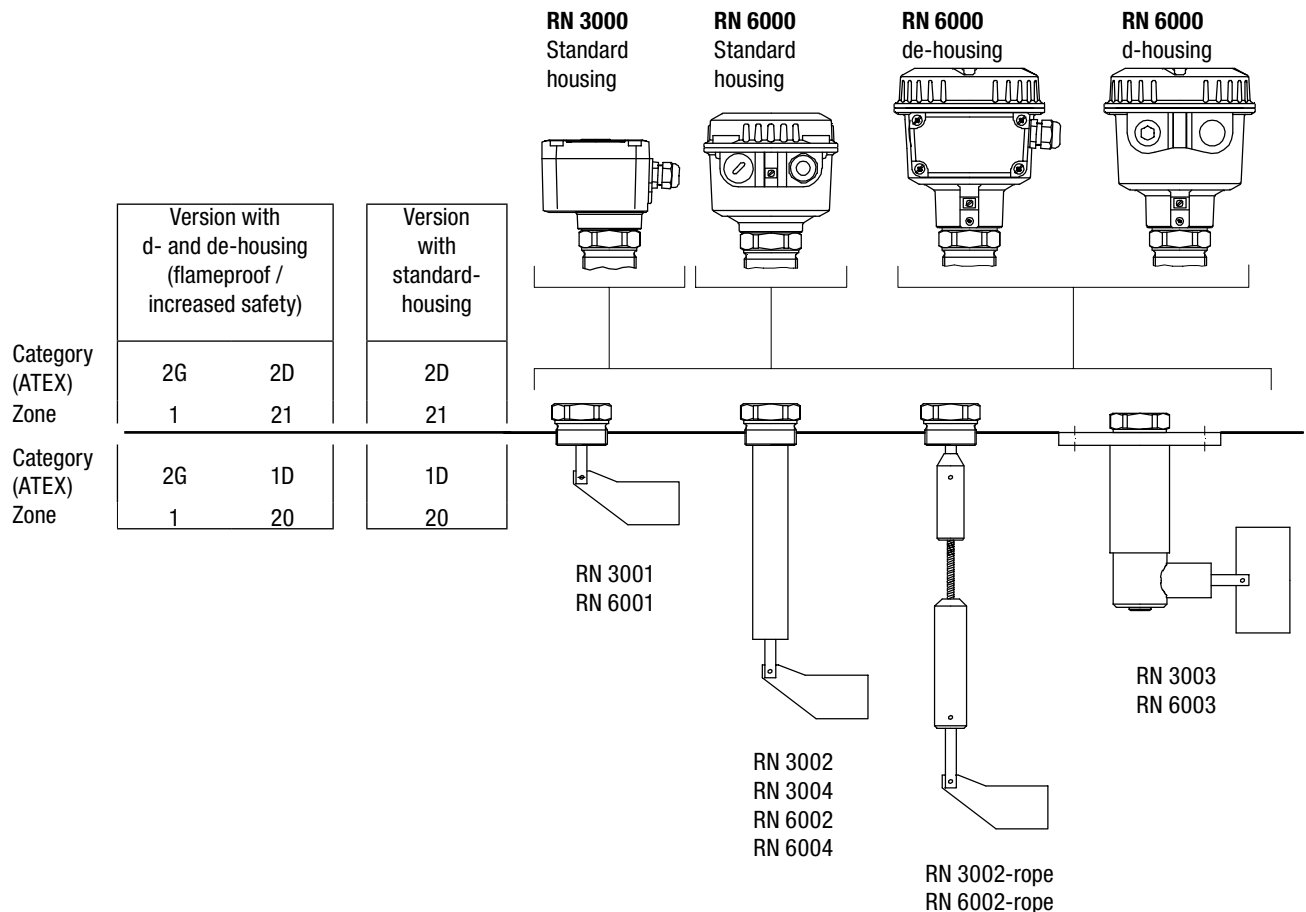

Notes for use in Hazardous Locations

Max. Surface Temperature and Temperature Code

The temperature marking on the name plate  refers to the instruction manual.
 In the following tables the relevant temperature ratings are shown.

The maximum surface temperature means the warmest area outside of the unit which can happen in failure case (according to EX definition).
 The temperature class means the warmest area anywhere outside or inside the unit which can happen in failure case (according to EX definition).

RN 3000

Ratings on the different versions

Enclosure directly mounted on the process connection		
Max. ambient temperature zone 21	Max. process temperature zone 20	Process or ambient side *
		Max. surface temperature
40°C (104°F)	50°C (122°F)	90°C (196°F)
50°C (122°F)	60°C (140°F)	100°C (212°F)
60°C (140°F)	70°C (158°F)	110°C (230°F)
70°C (158°F)	80°C (176°F)	120°C (248°F)

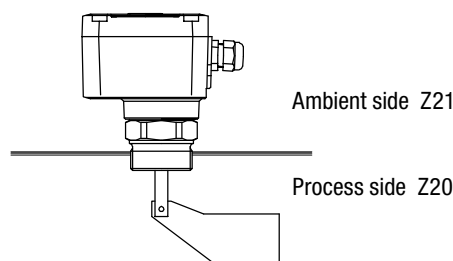

Enclosure mounted offset to the process connection		
Max. ambient temperature zone 21	Max. process temperature zone 20	Process or ambient side *
		Max. surface temperature
70°C (158°F)	90°C (194°F)	90°C (194°F)
	100°C (212°F)	100°C (212°F)
	110°C (230°F)	110°C (230°F)
	120°C (248°F)	120°C (248°F)
	130°C (266°F)	130°C (266°F)
	140°C (284°F)	140°C (284°F)
	150°C (302°F)	150°C (302°F)
	160°C (320°F)	160°C (320°F)
	170°C (338°F)	170°C (338°F)
	180°C (356°F)	180°C (356°F)
	190°C (374°F)	190°C (374°F)
	200°C (392°F)	200°C (392°F)
	210°C (410°F)	210°C (410°F)
220°C (428°F)	220°C (428°F)	

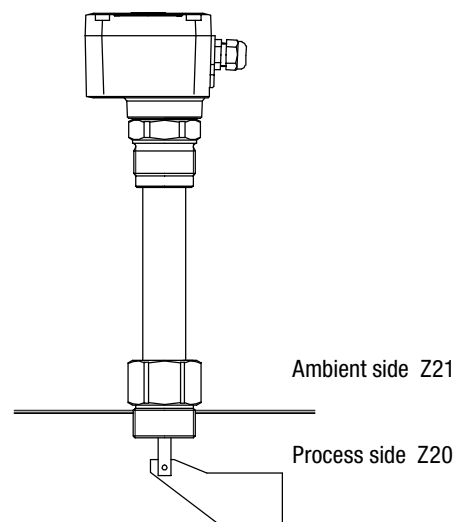

* Whichever temperature is higher

Notes for use in Hazardous Locations

RN 6000

Ratings on the different versions

Enclosure directly mounted on the process connection				
Max. ambient temperature	Max. process temperature	Process or ambient side *		
		Max. surface temperature	Temperature class (division system)	Temperature class (zone system)
40°C (104°F)	60°C (140°F)	100°C (212°F)	T5	T5
50°C (122°F)	70°C (158°F)	110°C (230°F)	T4A	T4
60°C (140°F)	80°C (176°F)	120°C (248°F)	T4A	T4

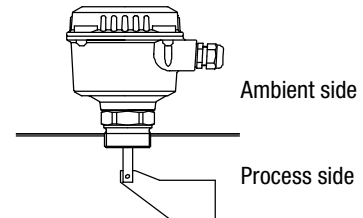

Enclosure mounted offset to the process connection				
Max. ambient temperature	Max. process temperature	Process or ambient side *		
		Max. surface temperature	Temperature class (division system)	Temperature class (zone system)
60°C (140°F)	90°C (194°F)	90°C (194°F)	T5	T5
	100°C (212°F)	100°C (212°F)	T5	T5
	110°C (230°F)	110°C (230°F)	T4A	T4
	120°C (248°F)	120°C (248°F)	T4A	T4
	130°C (266°F)	130°C (266°F)	T4	T4
	140°C (284°F)	140°C (284°F)	T3C	T3
	150°C (302°F)	150°C (302°F)	T3C	T3
	160°C (320°F)	160°C (320°F)	T3C	T3
	170°C (338°F)	170°C (338°F)	T3A	T3
	180°C (356°F)	180°C (356°F)	T3A	T3
	190°C (374°F)	190°C (374°F)	T3	T3
	200°C (392°F)	200°C (392°F)	T3	T3
	210°C (410°F)	210°C (410°F)	T2D	T2
	220°C (428°F)	220°C (428°F)	T2C	T2
	230°C (446°F)	230°C (446°F)	T2C	T2
240°C (464°F)	240°C (464°F)	T2B	T2	
250°C (482°F)	250°C (482°F)	T2B	T2	

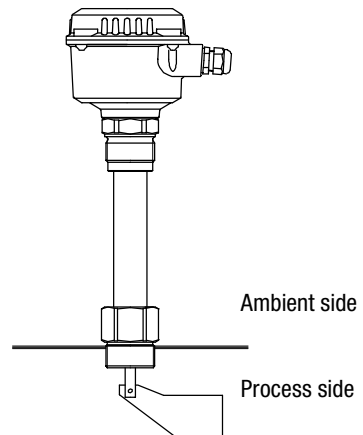

* Whichever temperature is higher