

Optoelectronic Liquid Level Limit Switches

Mini Limit Switches

Model OPTO.002X

Data Sheet OPTO.002X

Applications

- Level measurement for liquid media
- Level control and monitoring of defined levels
- Machine building
- Wastewater and environmental engineering

Special Features

- Very compact design, measurements also in small volumes
- Temperature range -30 ... +140 °C
- Designs for pressure range of vacuum to 50 bar



Mini Limit Switch Model OPTO.002X

Description

The optoelectronic liquid level limit switch is used for measuring liquid level limits. This is widely independent of physical characteristics such as refractive index, colour, specific gravity, dielectric permittivity and conductivity. It can also be used in transparent containers due to a good suppression of ambient light.

The PNP OC transistor output may be connected directly to the input of a control system or energise an external relay. The output is short-circuit proof and current, voltage and power limited.

The switching status can be read directly on the sensor (green LED).



General Data

Measuring accuracy	±0.5 mm
Light source	IR light 930 nm
Ambient light	max. 10,000 Lux
Minimum distance of glass tip to any opposite surface	>10 mm, >20 mm with electropolished surface
Mounting position	any
Optical control	
■ Switching status	green LED
■ Switching direction	to be set at factory
Weight	0.15 kg

Dimensions in mm

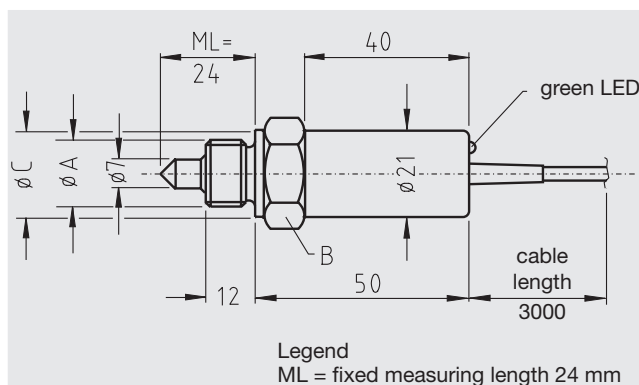

Design Data

Medium temperature	-30 ... +140 °C
Ambient temperature	-25 ... +70 °C
Working pressure	0 ... 5 MPa (0 ... 50 bar)
Materials	
■ Sensor case	stainless steel
■ Light guide	quartz glass
■ Packing	graphite/PTFE
■ Case	stainless steel

Selectable process connections

Process connection Ø A	Spanner width B	Sealing face Ø C
M16 x 1.5	SW24	21
G ½ A	SW30	26
½ NPT	SW24	-

Electrical Data

Supply voltage	24 V DC -25 ... +30 %
Max. current consumption	40 mA
Output	PNP OC transistor, short-circuit proof, current, voltage and power limitation
Switching current (Tu = 70 °C)	0.5 A
Electrical connection	<ul style="list-style-type: none"> ■ PVC cable 3 x 0.14 mm² ■ Connector 4-pole series 713, M12
Ingress protection	
■ With connector	IP 65 per EN 60 529
■ With cable	IP 66 per EN 60 529

Electrical connection diagram

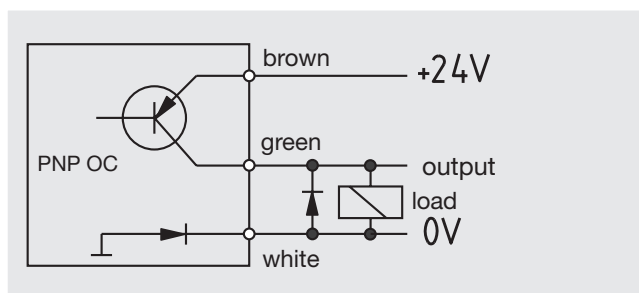

Connector assignment

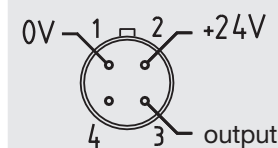

Ordering information

Model / Process connection / Electrical connection / Switching direction

Modifications may take place and materials specified may be replaced by others without prior notice. Specifications and dimensions given in this leaflet represent the state of engineering at the time of printing.

