

Datenblätter *Datasheets*
SCHAUGLASANZEIGER
Sight Glass Level Gauges

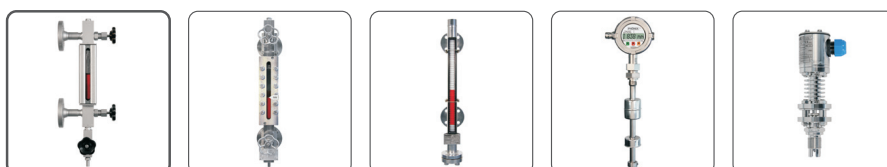
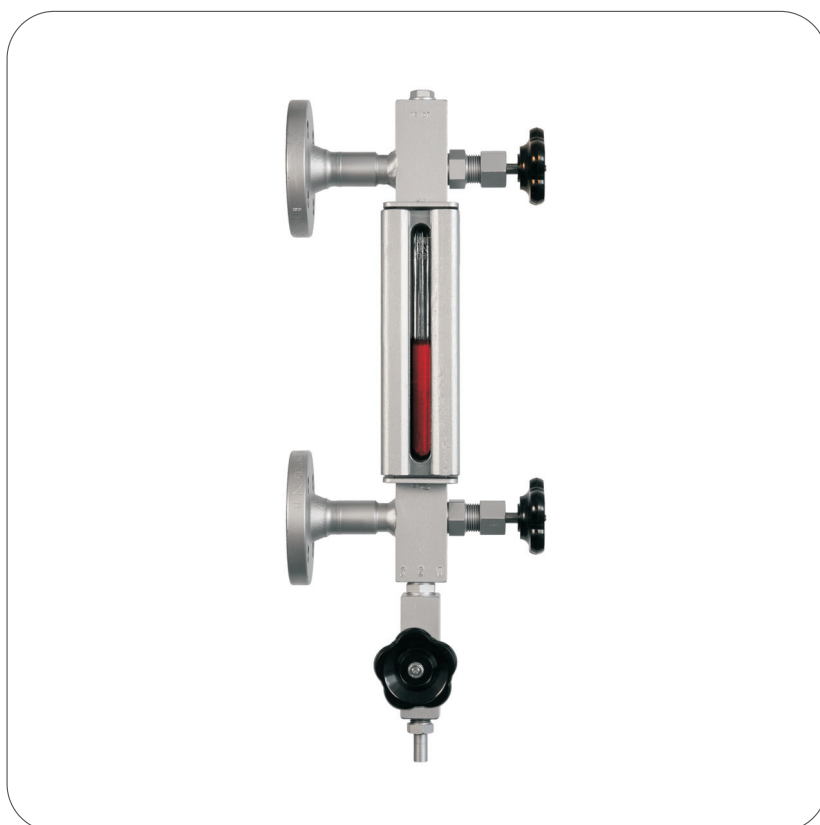

Funktionsprinzip Schauglasanzeiger

Reflexgläser nach DIN 7081

In Sichtrichtung einfallendes Licht trifft auf die Reflexrillen der Schauglasplatte und wird bei Flüssigkeit ins Medium weggebrochen und bei Gas reflektiert. Der Füllstand ist als dunkler Balken sichtbar, der Gasraum als silbriger Balken darüber.

Functional Description Sight Glass Level Gauges

Reflex glass type acc. to DIN 7081

Incident light is reflected at the reflex grooves of the sight glass plate covered by gas and is broken into the liquid in the part covered by medium. The liquid level is visible as a dark bar, the gaseous space as a silvery bar.

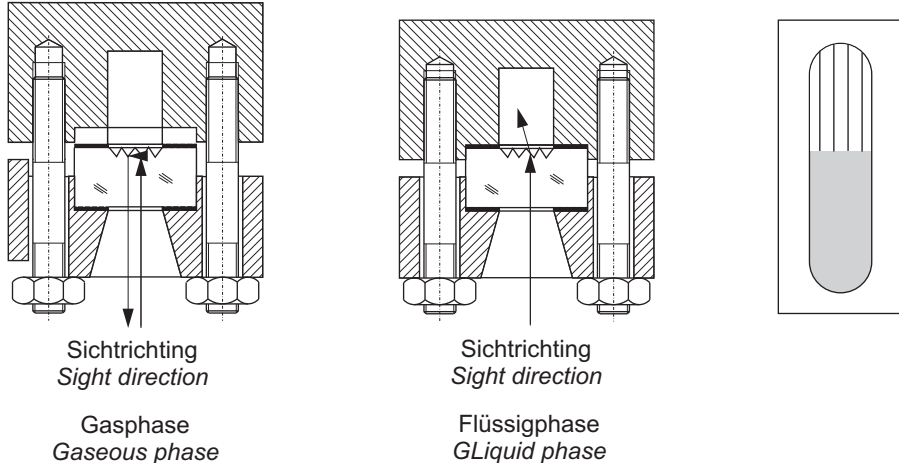

Transparentgläser nach DIN 7081

Entgegen der Sichtrichtung einfallendes Licht (Tageslicht oder das Licht einer Lampe) passiert beide Schauglasplatten mit dem dazwischen befindlichen Medium. Der Füllstand ist als Strich (Meniskus) bzw. anhand der Flüssigkeit selbst direkt sichtbar.

Transparent and reflex

Incident light (daylight or the light of a lamp) passed sight glass contrary to the view direction the medium situated between this. The filling level is itself direct as a line (meniscus) or with the liquid visible.

Refraktionsprinzip mit Glimmerscheiben

Entgegen der Sichtrichtung einfallendes Licht einer Lampe passiert beide Glimmerplatten in einem Winkel mit dem dazwischen befindlichen Medium. In Gasphase wird das Licht im Spalt geführt und durchstrahlt beide Glimmerpakete, bei Flüssigkeit wird das Licht weggebrochen. Der Füllstand ist als schwarzer Balken und der Gasraum als heller Balken ablesbar.

Refraction type with mica sheets

The incident light of a lamp is guided through the two mica sheet packages in an angle and passes the medium between them. In gaseous phase the light is guided straight forward and passes both mica packets, in liquid the light is refracted away. The liquid level is visible as a black bar and the gas as a bright bar.

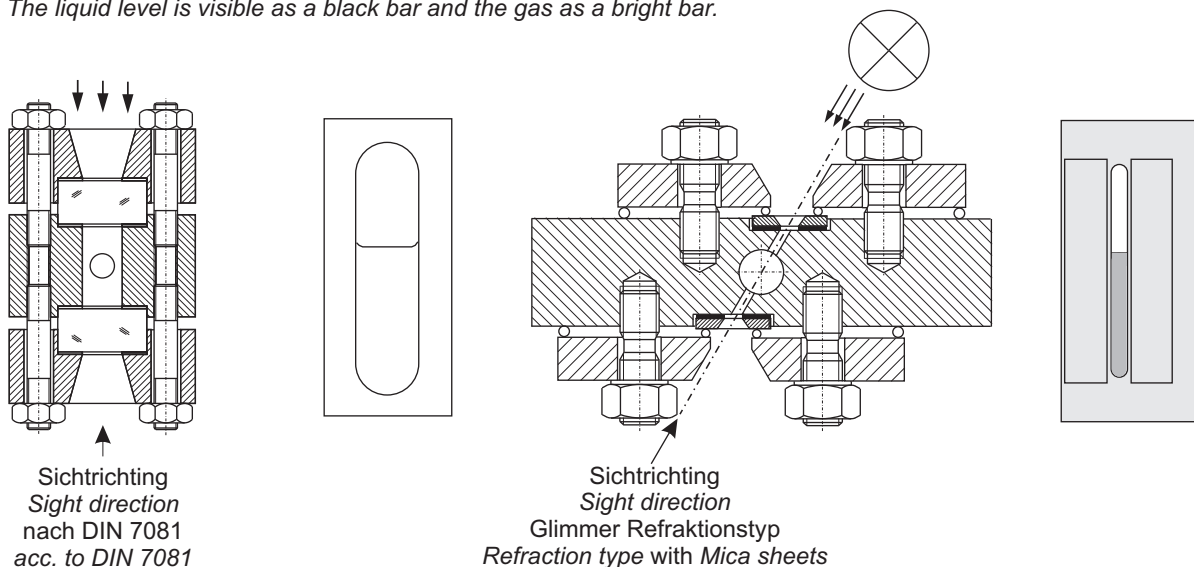

Sight Glass Level Gauge

Contents

General

Design
Gauge valves essentials
Arrangement of sections

Data sheets sight glass level gauges

Basic type	Press. rating	Body type	Connection	Gauge valve	internal conn.	Actuation
700.12	CL 600	reflex, transparent	side-side fixed	760.51 .. 52	nipple	handwheel
700.12XXA	CL 900	reflex, transparent	side-side fixed	760.51 .. 52	nipple	handwheel
700.13	CL 600	reflex, transparent	side-side fixed	760.56 .. 57	nipple	quick closing
700.13XXA	CL 900	reflex, transparent	side-side fixed	760.56 .. 57	nipple	quick closing
700.21	CL 600	reflex, transparent	top-bottom pivoted	760.53	nipple	handwheel
700.21XXA	CL 900	reflex, transparent	top-bottom pivoted	760.53	nipple	handwheel
700.23	CL 600	reflex, transparent	top-bottom pivoted	760.58	nipple	quick closing
700.23XXA	CL 900	reflex, transparent	top-bottom pivoted	760.58	nipple	quick closing
700.26	CL 1500	reflex, transparent	side-side fixed	760.51 .. 52	nipple	handwheel
700.27	CL 1500	reflex, transparent	top-bottom pivoted	760.53	nipple	handwheel
700.46	CL150	reflex, transparent, large chamber	top-bottom	without/with		
700.31	CL600	reflex, transparent, open back, bridgeweld-pad	top-bottom	without		
700.B1	CL300	reflex, side plates, hinged	side-side fixed	integrated		handwheel
700.B5	CL300	reflex, side plates, hinged	top-bottom			lever
700.B7	CL300	reflex, pressure frame, 15° diagonally	backside			lever
700.C0	CL300	transparent	backside	integrated		handwheel
700.C4	CL 600	transparent	backside	integrated		handwheel
700.C5	CL 600	transparent	backside	760.68	union	lever
700.C6	CL up to 600	reflex, transparent	side-side fixed	760.18	flanged	handwheel + lever
700.C7	CL 600	red - green	backside	760.68	union	lever
700.C8	CL 600	refraction, mica	backside	760.18	union	handwheel + lever
700.CA	CL 1500	refraction, mica	backside	760.19	union	handwheel + lever
700.A1	CL150	glass tube 13,5 mm, steel, glass prot.	top-bottom pivoted		screwed	handwheel
700.A2	CL150	glass tube 13,5 mm, brass, glass prot.	top-bottom pivoted		screwed	handwheel
700.A3	CL150	glass tube 13,5 mm, glass prot.	top-bottom pivoted		screwed	handwheel
700.A4	CL150	glass tube 13,5 mm, glass prot.	top-bottom pivoted	without	screwed	handwheel
700.01	CL150	glass tube 16 mm, glass prot., GH *)	top-bottom pivoted	760.01	screwed	handwheel
700.03	CL150	glass tube 16 mm, glass prot., GH *)	top-bottom pivoted	760.03	screwed	lever

*) GH = Glass holder in-between

Data sheets gauge valve

Type	press. rating	Actuation	connection body	thruway	pattern	stem thread
760.51	CL 1500	handwheel	union	straight	inline	inside
760.52	CL 1500	handwheel	union	angle	inline	inside
760.53	CL 1500	handwheel	union	angle	offset	inside
760.56	CL 900	quick closing lever	union	straight	inline	inside
760.57	CL 900	quick closing lever	union	angle	inline	inside
760.58	CL 900	quick closing lever	union	angle	offset	inside
760.01	CL 1500	handwheel	union	angle	offset	inside
760.03	CL 900	quick closing lever	union	angle	offset	inside
760.11	CL300	quick closing lever	union	angle	inline	inside
760.18	CL 900	handwheel/lever	union	angle	inline	inside
760.19	CL 1500	handwheel/lever	union	angle	inline	inside
760.68	CL 900	quick closing lever	union	straight	inline	inside

Data sheets accessories

709.0XXX Illumination direct irradiation
Frost protection, glasses, seals
Mica sheets, seals for mica, set of mica, corrosion protection, low water level pointer
corrosion protection, scale, heating
700.VAR process connection, drain, vent



Sight Glass Level Gauges

General

Level Gauges for direct reading of liquid levels in vessels and tanks

Large variety of technically interesting types, to be used in:

- Refineries
- Off-shore
- Oil and gas
- Power stations
- Chemical plants
- Thermofluid oil installations
- Refrigerating plants
- Cryogenic services

Product groups:

- reflex type
- transparent type with glass or mica
- refraction type
- tubular type

Shut-off valves:

- handwheel or quick closing lever
- with ball check
- flanged or union connection

Chambers:

- fixed, flanged, pivoted, screwed or weldable
- interrupted or continuous visible length

Accessories:

- Drain and vent
- Illumination
- Heating
- scale
- frost protection
- Ultraviolet protection
- corrosion protection
- Lining/coating PTFE/Halar, rubber

Rating:

- Pressure rating PN 6 - 250
- Operating temperatures from -200 up to 450 °C

Materials:

- Forged steel, stainless steel, suitable for pressure equipment according to EN or ASME
- particularly corrosion resistant materials as Duplex, Monel, Inconel, Hastelloy, Titanium, etc.

Certificates:

- Test certificates according to DIN EN 10204
- Sour gas regulation NACE
- Tests to customers requirements

Necessary data:

Operation and design pressure (p), operation and design temperature (T), center to center distance (ME), visible length (SL), materials, medium, connection type for process and heating, type of illumination, quantity.

Special constructions available upon request
For further details please use our datasheets



Sight Glass Level Gauges

Design

The main part of the sight glass level gauge is the chamber. A duct for the medium (or heating agent) is machined into the gauge body as well as the support surfaces for the gaskets and glasses or micas. Glass plates and/or micas are mounted with gasket and cushion and are fixed with the cover plate or pressure frames and bolts. The glass plates used for sight glass level gauges correspond to DIN 7081 and are suitable for temperatures up to 243 °C (280 °C when protected with mica) for steam, up to 300 °C for other liquids, and in special cases up to 450 °C. Borosilicate glass is standard quality. For conditions above the natural mineral mica is used. The process connection normally is equipped with gauge valves. Drain valves are used for draining the gauge and are generally mounted on the lower end of the gauge body. In Special cases a vent valve can be installed on the upper end.

Gauge body

Contains the liquid duct, the level corresponds with the level in the vessel.

Cover

Clamping for Glass plate.

Gasket

Recessed sealing between liquid duct and ambient

Glass

Glass plates according to DIN 7081, made of Borosilicate-Glass, quartz, Aluminum silicate

Cushion

Mechanical protection between cover and glass

Bolt / Nut

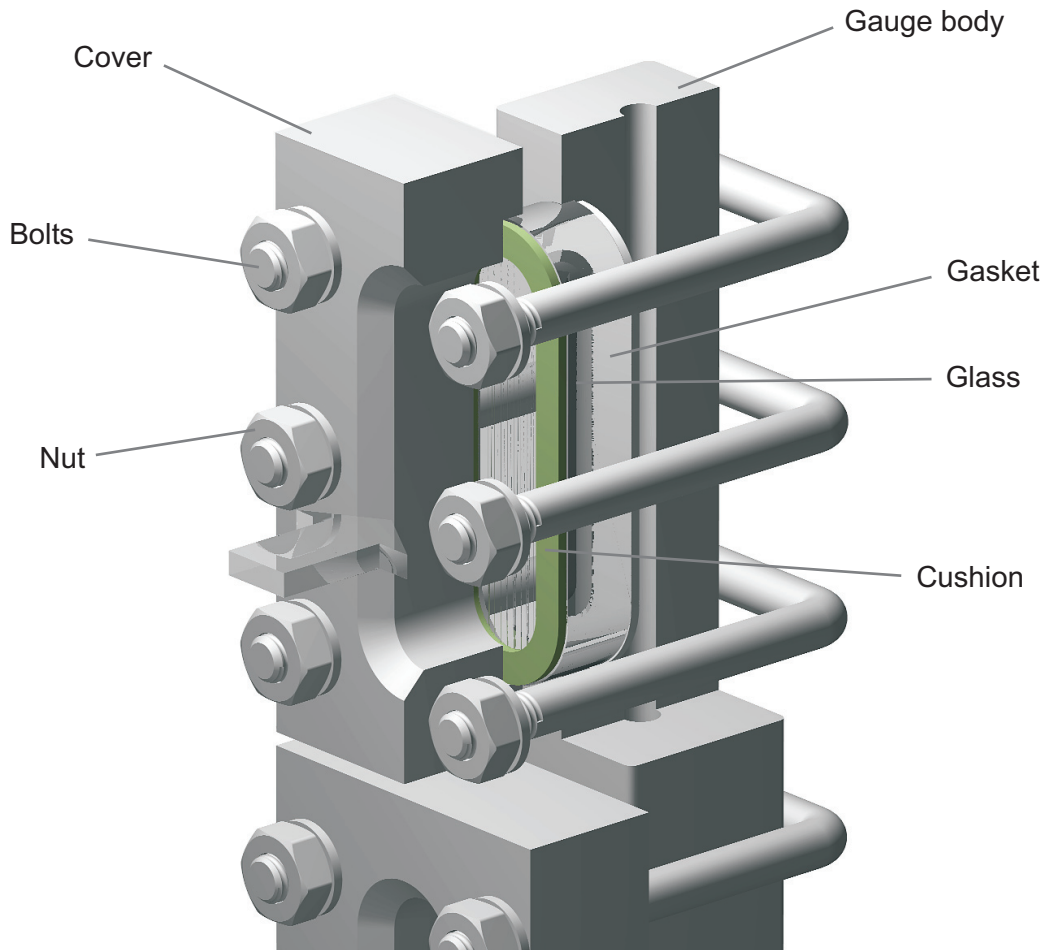

Design in principle



Sight glass level gauges

Gauge valves essentials

The gauge valves are used to shut off the vessel against the level gauge. The actuation can be done by a lever (120°) or a handwheel. All gauge valves are equipped with a ball check as a safety device.

Functional principle ball check

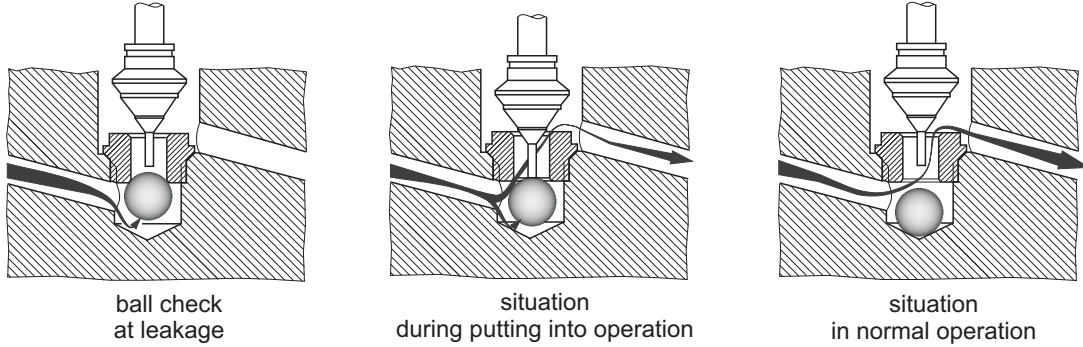

The ball check is a safety device which is used in all gauge valves. It's task is to avoid heavy leakage after breaking of a glass or mica window or leakages due to other reasons. The ball is located below the seat. As soon as there is leakage causing flow of liquid, the ball is driven to the seat by the liquid ($\Delta p > 0,5 \text{ bar}$). This closes the valve and stops heavy leakage.

Operation directions of quick closing valve and handwheel

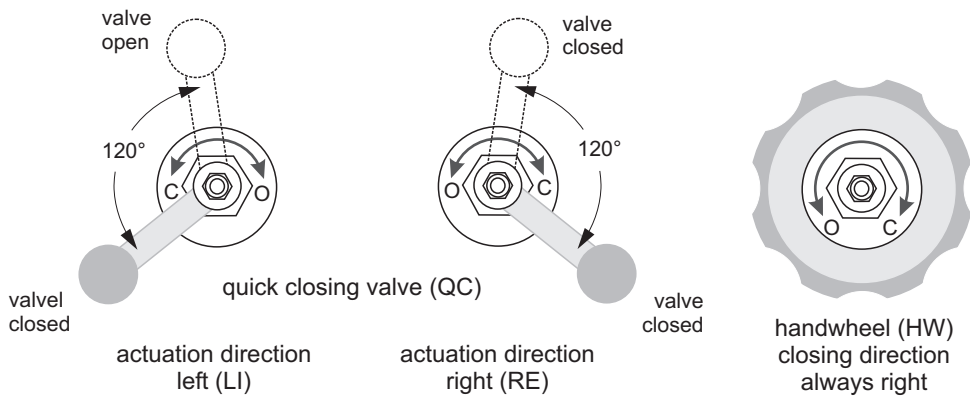

View direction onto vessel

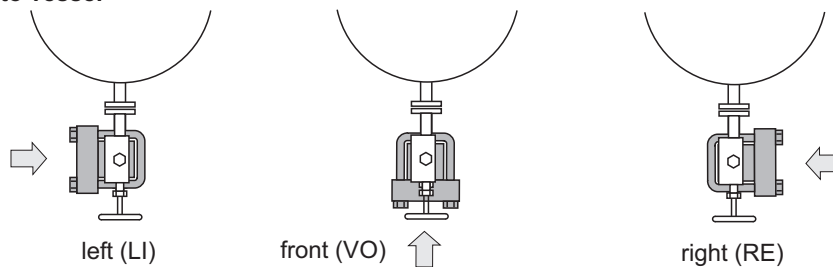

Complete specification for view direction and valve orientation

view direction - actuation direct. - valve actuator - valve type

e. g. view direction left, actuation direction right, quick closing, angle type:

LI-RE-SS-angle



Sight glass level gauges

Arrangement of Sections

Flat glasses acc. to DIN 7081

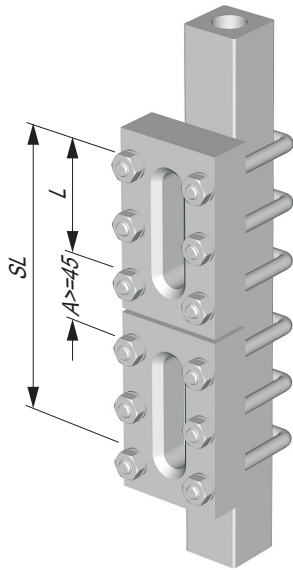

normal indication interrupted

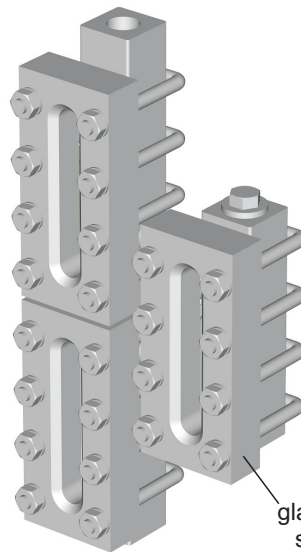

uninterrupted indication with bypass

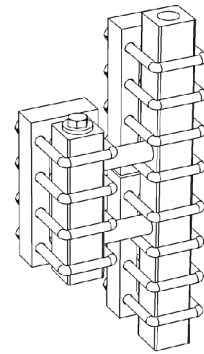

backside view

Visible length and glass type

Glass type	0	1	2	3	4	5	6	7	8	9	10	11	12	13	14	15	16	17	18	19	20
L	75	95	120	145	170	200	230	260	300	320	350	380	410	440	480	510	540	580	610	640	680
L + A	120	140	165	190	215	245	275	305	345	365	395	425	455	485	525	555	585	625	655	685	725

		Visible length SL																				
nos of segments n	1	75	95	120	145	170	200	230	260	300	320	350	380	410	440	480	510	540	580	610	640	680
	2	195	235	285	335	385	445	505	565	645	685	745	805	865	925	1005	1065	1125	1205	1265	1325	1405
	3	315	375	450	525	600	690	780	870	990	1050	1140	1230	1320	1410	1530	1620	1710	1830	1920	2010	2130
	4	435	515	615	715	815	935	1055	1175	1335	1415	1535	1655	1775	1895	2055	2175	2295	2455	2575	2695	2855
	5	555	655	780	905	1030	1180	1330	1480	1680	1780	1930	2080	2230	2380	2580	2730	2880	3080	3230	3380	3580
	6	675	795	945	1095	1245	1425	1605	1785	2025	2145	2325	2505	2685	2865	3105	3285	3465	3705	3885	4065	4305
	7	795	935	1110	1285	1460	1670	1880	2090	2370	2510	2720	2930	3140	3350	3630	3840	4050	4330	4540	4750	5030
	8	915	1075	1275	1475	1675	1915	2155	2395	2715	2875	3115	3355	3595	3835	4155	4395	4635	4955	5195	5435	5755
	9	1035	1215	1440	1665	1890	2160	2430	2700	3060	3240	3510	3780	4050	4320	4680	4950	5220	5580	5850		
	10	1155	1355	1605	1855	2105	2405	2705	3005	3405	3605	3905	4205	4505	4805	5205	5505	5805				
	11	1275	1495	1770	2045	2320	2650	2980	3310	3750	3970	4300	4630	4960	5290	5730						
	12	1395	1635	1935	2235	2535	2895	3255	3615	4095	4335	4695	5055	5415	5775							

Matrix valid for A=45

we recommend max. 7 segments and above that use multiple gauges



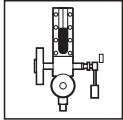

Sight glass level gauge CL150 to 600

Light execution
 Reflex, Transparent
 Connection side-side fixed
 Connection gauge valve to gauge chamber: flange
 Quick closing

Product group **700**

Type **10**

Sheet: 13 Revision: 0

Date: 02/05

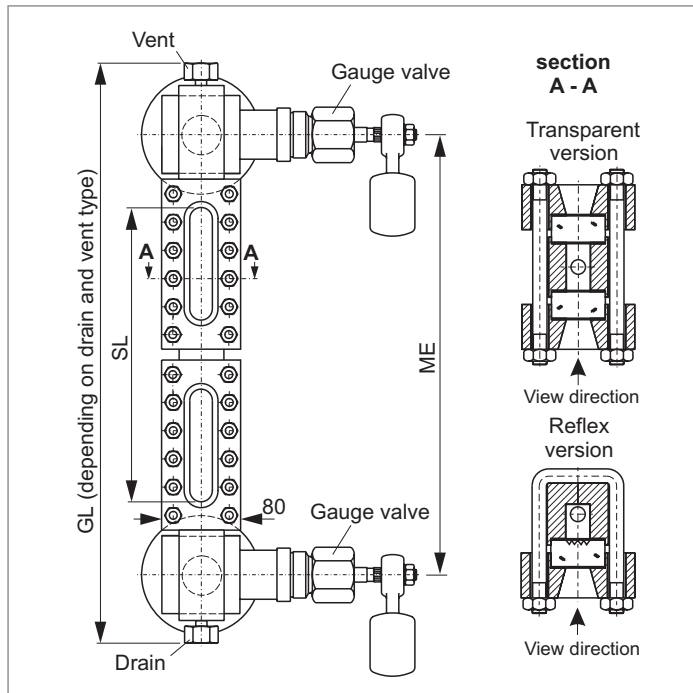

Field of Application

Direct reading liquid level indicator for general applications up to CL600 (depends on glass type). Increased safety with ball check valves.

General Data

Visible length SL
 Reflex / transparent: ME / ME-130* mm
 Body: 40 x 40, 40 (for special materials)
 Connection gauge valve - body: flange
 Gauge valve types: s. data sheet 760.14/15/16/17
 Actuation: quick closing
 Material glass plates acc. to DIN 7081: Borosilicate
 Material media wetted parts: CS, SS
 Depending on delivery situation material can vary.
 Types with special materials e. g. Hastelloy, Monel etc. are available.
 Weight
 - basic weight (glass type 4-9)
 reflex / transparent: 17.0-19.3 kg / 20.0-24.0 kg
 - per segment (glass type 4-9)
 reflex / transparent: 6.8-11.5 kg / 8.2-12.8 kg
 Depending on execution weight can vary.

Design Data

Design pressure/-temperature see derating
 - D40, reflex: data sheet BG00R0
 - 40 x 40, reflex, transparent: data sheet BG00R1

Further Data

Connection gauge valve - body: see 700.VAR
 Process connection: see 700.VAR
 Vent: see 700.VAR
 Drain: see 700.VAR

Accessories

Glass protection etc.: see accessories
 Frosts protection: see accessories
 Illumination: see accessories
 Scale: see accessories
 Heating: see accessories

CS (= carbon steel) and SS (= stainless steel type 316SS) are materials suitable for Pressure Vessels according to EN or ASME.

Subject to alterations

Orientation of gauge valve and operation

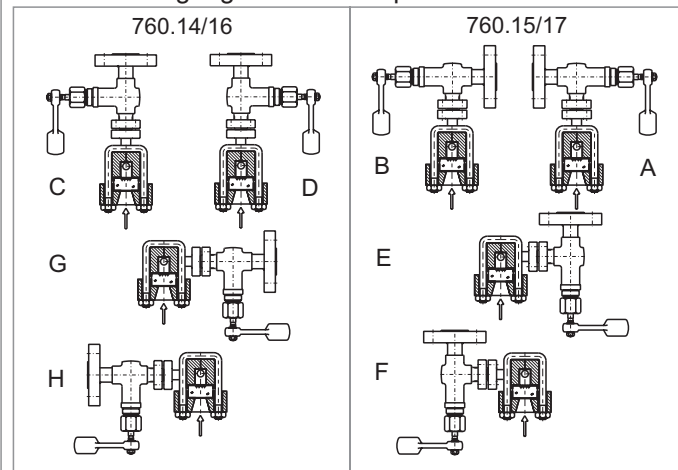

Ordering no.

7 0 0 1 0 X X X X X X X X - X X - X X X X X X X X X X - X X X X X		see 700.VAR	ME [mm]
bridging	without	0	results from SL
	with	1	X spec. glass types
glass window	Reflex (DIN 7081)	1	X X nos of segments
	Transparent (DIN 7081)	2	DIN-bolts, -nuts
gauge valve	760.14	1 4	A ANSI-bolts, -nuts
	760.15	1 5	0 D40 (for special materials)
	760.16	1 6	1 40 x 40 DIN 7081
	760.17	1 7	X see above and data sheet 760.14/15/16/17
			DIN/ASME
			gauge body
			orientation gauge valve



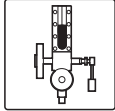

Sight glass level gauge CL150 to 600

Light execution
 Reflex, Transparent
 Connection side-side fixed
 Connection gauge valve to gauge chamber: union
 Hand wheel

Product group **700**

Type **12**

Sheet: 1

Revision: 0

Date:

08/2011

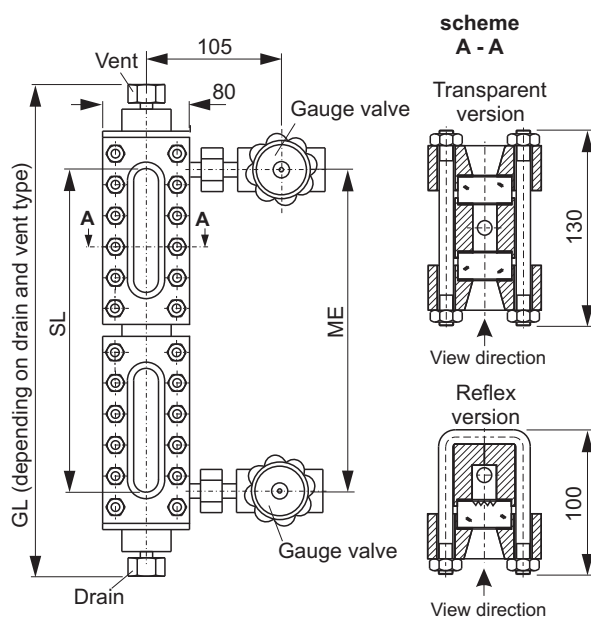

Field of Application

Direct reading liquid level indicator for general applications up to CL600 (depends on glass type). Increased safety with ball check valves.

General Data

Visible length SL: \leq ME
 Connection gauge valve - body: union
 Gauge valve types: see data sheet 760.51/52
 Actuation: hand wheel
 Material glass plates acc. to DIN 7081: Borosilicate
 Material media wetted parts: CS, SS
 Depending on delivery situation material can vary.
 Types with special materials e. g. Hastelloy, Monel etc. are available.

Design Data

Derating depends on temperature and window size

Further Data

Connection gauge valve - body: see 700.VAR
 Process connection: see 700.VAR
 Vent: see 700.VAR
 Drain: see 700.VAR

Accessories

Glass protection etc.: see accessories
 Frosts protection: see accessories
 Illumination: see accessories
 Scale: see accessories
 Heating: see accessories

Orientation of gauge valve and operation

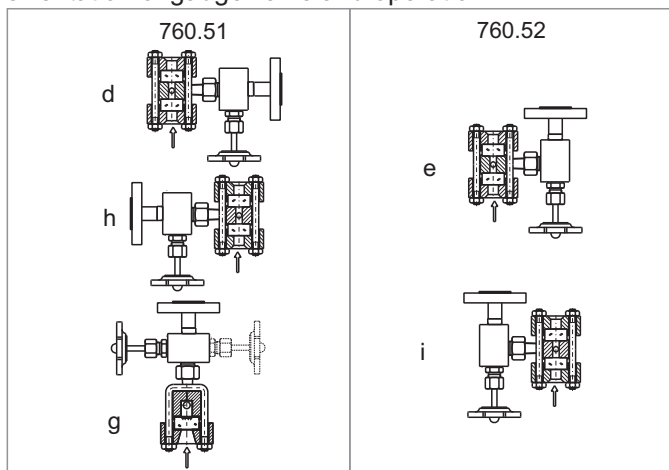

CS (= carbon steel) and SS (= stainless steel type 316SS) are materials suitable for Pressure Vessels according to EN or ASME.

Subject to alterations

Ordering no.

7 0 0 1 2 X X X X X X X X - X X - X X X X X X X X X X - X X X X X		see 700.VAR	ME [mm]
bridging	without	0	results from ME
	with	1	
glass window	Reflex (DIN 7081)	1	nos of segments
	Transparent (DIN 7081)	2	
gauge valve	760.51	5 1	DIN-bolts, -nuts
	760.52	5 2	A ANSI-bolts, -nuts
		X	X depends on design pressure
			see data sheet 760.51/52
			glass type
			DIN/ASME
			gauge body
			orientation gauge valve



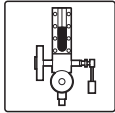

Sight glass level gauge up to CL900

Light execution
 Reflex, Transparent
 Connection side-side fixed
 Connection gauge valve to gauge chamber: union
 Hand wheel

Product group **700**

Type **12XXA**

Sheet: 1 Revision: 0

Date: 08/2011

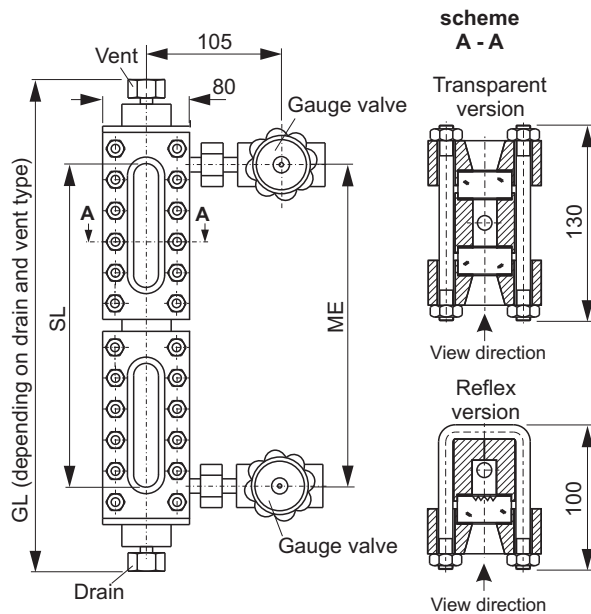

Field of Application

Direct reading liquid level indicator for general applications up to CL900 (depends on glass type). Increased safety with ball check valves.

General Data

Visible length SL: \leq ME
 Connection gauge valve - body: union
 Gauge valve types: see data sheet 760.51/52
 Actuation: hand wheel
 Material glass plates acc. to DIN 7081: Borosilicate
 Material media wetted parts: CS, SS
 Depending on delivery situation material can vary.
 Types with special materials e. g. Hastelloy, Monel etc. are available.

Design Data

Derating depends on temperature and window size

Further Data

Connection gauge valve - body: see 700.VAR
 Process connection: see 700.VAR
 Vent: see 700.VAR
 Drain: see 700.VAR

Accessories

Glass protection etc.: see accessories
 Frosts protection: see accessories
 Illumination: see accessories
 Scale: see accessories
 Heating: see accessories

Orientation of gauge valve and operation

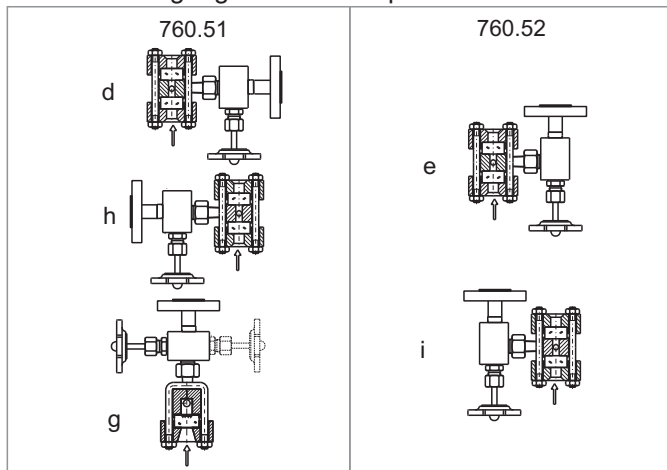

CS (= carbon steel) and SS (= stainless steel type 316SS) are materials suitable for Pressure Vessels according to EN or ASME.

Subject to alterations

Ordering no.

		see 700.VAR										ME [mm]			
		7 0 0 1 2 X X A X X X X X - X X - X X X X X X X X X - X X X X													
												results from ME		glass type	
												X X nos of segments			
												DIN-bolts, -nuts		DIN/ASME	
												A ANSI-bolts, -nuts			
												X depends on design pressure			
												760.51		5 1	
												760.52		5 2 X	
												see data sheet 760.51/52			
bridging		without		0		with		1							
glass window		Reflex (DIN 7081)		1		Transparent (DIN 7081)		2							
gauge valve		760.51		5 1		760.52		5 2 X							



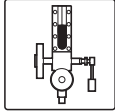

Sight glass level gauge CL150 to 600

Light execution
 Reflex, Transparent
 Connection side-side fixed
 Connection gauge valve to gauge chamber: union
 Quick closing

Product group **700**

Type **13**

Sheet: 1 Revision: 0

Date: 08/2011

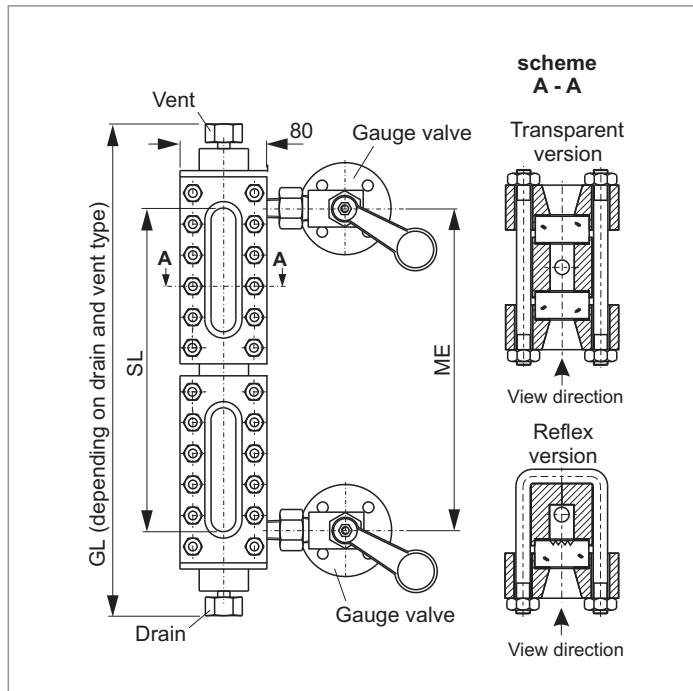

Field of Application

Direct reading liquid level indicator for general applications up to CL600 (depends on glass type). Increased safety with ball check valves.

General Data

Visible length SL: \leq ME
 Connection gauge valve - body: union
 Gauge valve types: see data sheet 760.56/57
 Actuation: quick closing
 Material glass plates acc. to DIN 7081: Borosilicate
 Material media wetted parts: CS, SS
 Depending on delivery situation material can vary.
 Types with special materials e. g. Hastelloy, Monel etc. are available.

Design Data

Derating depends on temperature and window size

Further Data

Connection gauge valve - body: see 700.VAR
 Process connection: see 700.VAR
 Vent: see 700.VAR
 Drain: see 700.VAR

Accessories

Glass protection etc.: see accessories
 Frosts protection: see accessories
 Illumination: see accessories
 Scale: see accessories
 Heating: see accessories

Orientation of gauge valve and operation

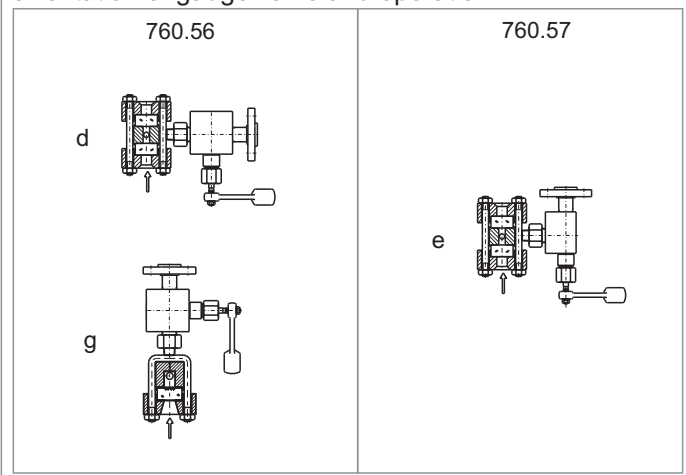

CS (= carbon steel) and SS (= stainless steel type 316SS) are materials suitable for Pressure Vessels according to EN or ASME.

Subject to alterations

Ordering no.

7 0 0 1 3 X X X X X X X X - X X - X X X X X X X X X X - X X X X X		see 700.VAR	ME [mm]
bridging	without	0	results from ME
	with	1	
glass window	Reflex (DIN 7081)	1	nos of segments
	Transparent (DIN 7081)	2	
gauge valve	760.56	5 6	DIN-bolts, -nuts
	760.57	5 7	A ANSI-bolts, -nuts
		X	X depends on design pressure
			see data sheet 760.56/57
			glass type
			DIN/ASME
			gauge body
			orientation
			gauge valve



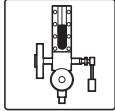

Sight glass level gauge CL600

Light execution
 Reflex, Transparent
 Connection side-side fixed
 Connection gauge valve to gauge chamber: union
 Quick closing

Product group **700**

Type **13XXA**

Sheet: 1

Revision: 0

Date:

08/2011

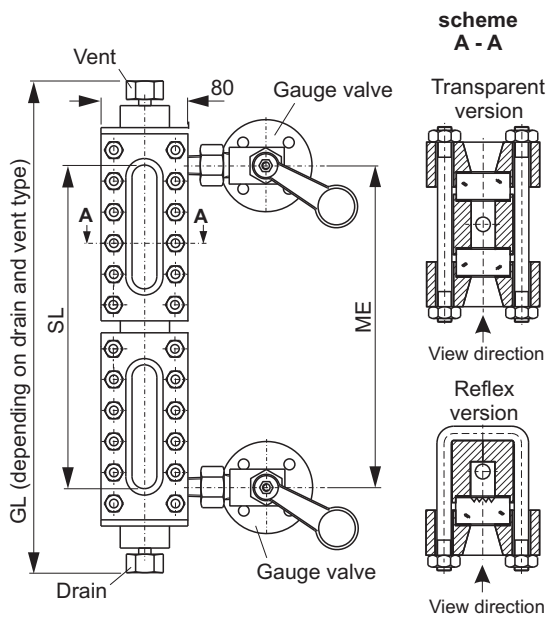

Field of Application

Direct reading liquid level indicator for general applications up to CL600 (depends on glass type). Increased safety with ball check valves.

General Data

Visible length SL: \leq ME
 Connection gauge valve - body: union
 Gauge valve types: see data sheet 760.56/57
 Actuation: quick closing
 Material glass plates acc. to DIN 7081: Borosilicate
 Material media wetted parts: CS, SS
 Depending on delivery situation material can vary.
 Types with special materials e. g. Hastelloy, Monel etc. are available.

Design Data

Derating depends on temperature and window size

Further Data

Connection gauge valve - body: see 700.VAR
 Process connection: see 700.VAR
 Vent: see 700.VAR
 Drain: see 700.VAR

Accessories

Glass protection etc.: see accessories
 Frosts protection: see accessories
 Illumination: see accessories
 Scale: see accessories
 Heating: see accessories

Orientation of gauge valve and operation

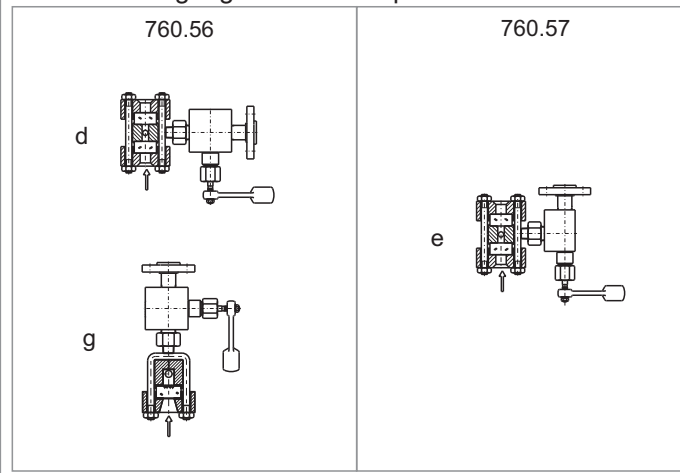

CS (= carbon steel) and SS (= stainless steel type 316SS) are materials suitable for Pressure Vessels according to EN or ASME.

Subject to alterations

Ordering no.

70013XXAXXX-XX-XXXXXX-XXXXX		see 700.VAR	ME [mm]
bridging	without	0	glass type
	with	1	
glass window	Reflex (DIN 7081)	1	DIN/ASME
	Transparent (DIN 7081)	2	
gauge valve	760.56	5 1	gauge body
	760.57	5 2 X	
X see data sheet 760.56/57			
		X X nos of segments	
		DIN-bolts, -nuts	
		A ANSI-bolts, -nuts	
		X depends on design pressure	
		results from ME	
		X spec. glass types	



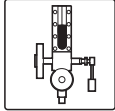

Sight glass level gauge CL150 to 600

Light execution
 Reflex, Transparent
 Connection top-bottom pivoted
 Connection gauge valve to gauge chamber: union
 Offset, handwheel

Product group **700**

Type **21**

Sheet: 1 Revision: 0

Date: 08/2011

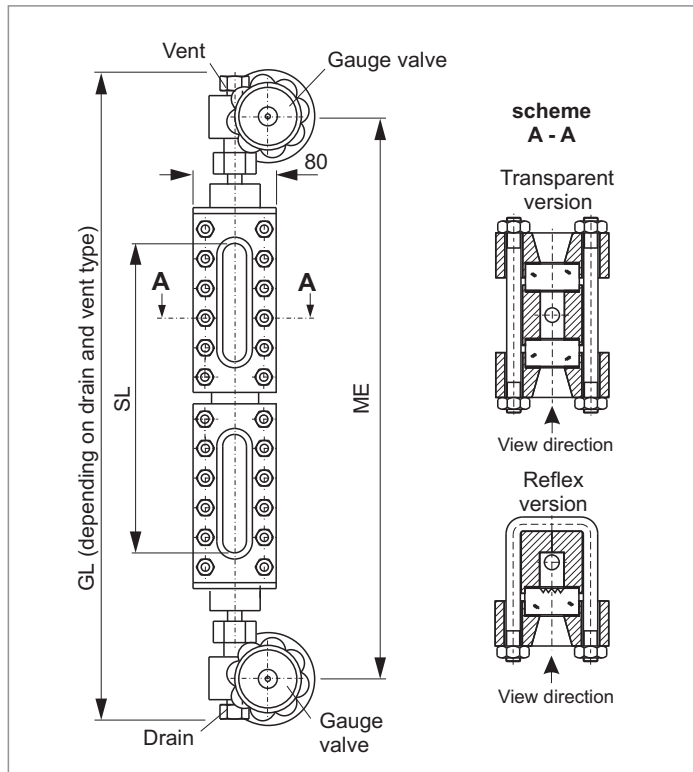

Field of Application

Direct reading liquid level indicator for general applications up to CL600 (depends on glass type). Increased safety with ball check valves.

General Data

Visible length SL: <ME - 180 mm
 Connection gauge valve - body: union
 Gauge valve types: see data sheet 760.53
 Actuation: hand wheel
 Material glass plates acc. to DIN 7081: Borosilicate
 Material media wetted parts: CS, SS
 Depending on delivery situation material can vary.
 Types with special materials e. g. Hastelloy, Monel etc. are available.

Design Data

Derating depends on temperature and window size

Further Data

Connection gauge valve - body: see 700.VAR
 Process connection: see 700.VAR
 Vent: see 700.VAR
 Drain: see 700.VAR

Accessories

Glass protection etc.: see accessories
 Frosts protection: see accessories
 Illumination: see accessories
 Scale: see accessories
 Heating: see accessories

Orientation of gauge valve and operation

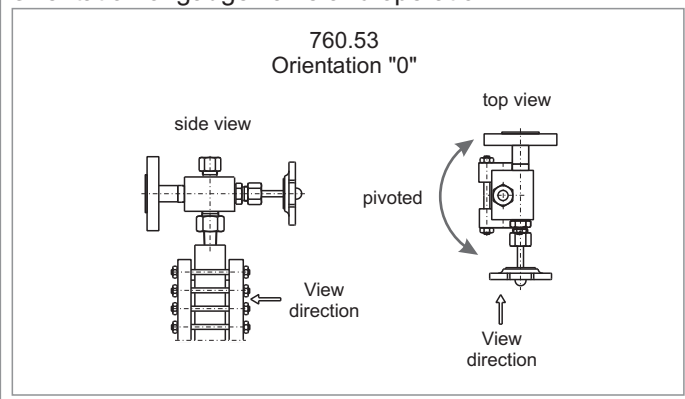

CS (= carbon steel) and SS (= stainless steel type 316SS) are materials suitable for Pressure Vessels according to EN or ASME.

Subject to alterations

Ordering no.

7 0 0 2 1 X X 5 3 0 X X - X X - X X X X X X X X X - X X X X		see 700.VAR	ME [mm]
bridging	without	0	results from ME
	with	1	X spec. glass types
glass window	Reflex (DIN 7081)	1	X X nos of segments
	Transparent (DIN 7081)	2	DIN-bolts, -nuts
gauge valve	760.53	5 3 0	A ANSI-bolts, -nuts
			X depends on design pressure
			see data sheet 760.53
			orientation gauge valve



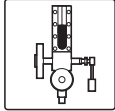

Sight glass level gauge CL900

Light execution
 Reflex, Transparent
 Connection top-bottom pivoted
 Connection gauge valve to gauge chamber: union
 Offset, handwheel

Product group **700**

Type **21XXA**

Sheet: 1

Revision: 0

Date:

08/2011

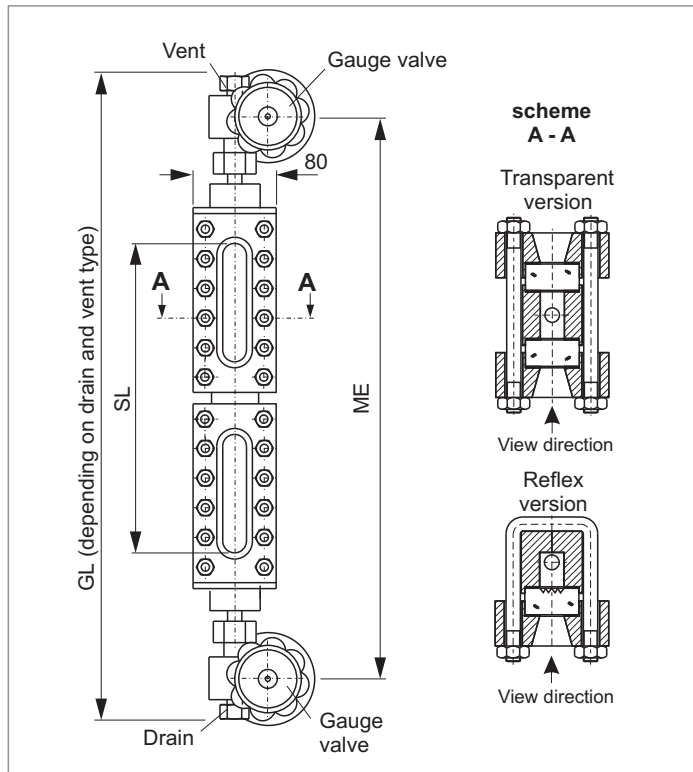

Field of Application

Direct reading liquid level indicator for general applications up to CL900 (depends on glass type). Increased safety with ball check valves.

General Data

Visible length SL: <ME - 180 mm
 Connection gauge valve - body: union
 Gauge valve types: see data sheet 760.53
 Actuation: hand wheel
 Material glass plates acc. to DIN 7081: Borosilicate
 Material media wetted parts: CS, SS
 Depending on delivery situation material can vary.
 Types with special materials e. g. Hastelloy, Monel etc. are available.

Design Data

Derating depends on temperature and window size

Further Data

Connection gauge valve - body: see 700.VAR
 Process connection: see 700.VAR
 Vent: see 700.VAR
 Drain: see 700.VAR

Accessories

Glass protection etc.: see accessories
 Frosts protection: see accessories
 Illumination: see accessories
 Scale: see accessories
 Heating: see accessories

Orientation of gauge valve and operation

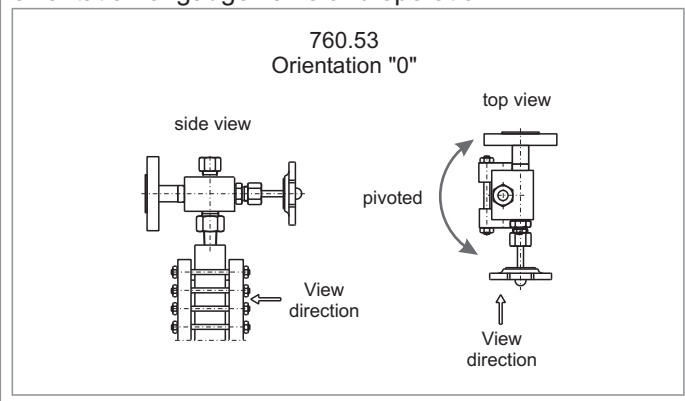

CS (= carbon steel) and SS (= stainless steel type 316SS) are materials suitable for Pressure Vessels according to EN or ASME.

Subject to alterations

Ordering no.

7 0 0 2 1 X X A 5 3 X X X - X X - X X X X X X X X X - X X X X			see 700.VAR	ME [mm]	
bridging	without	0	X X nos of segments	results from ME	glass type
	with	1		X spec. glass types	
glass window	Reflex (DIN 7081)	1	DIN-bolts, -nuts	DIN/ASME	
	Transparent (DIN 7081)	2	A ANSI-bolts, -nuts	gauge body	
gauge valve	760.53	5 3	X depends on design pressure		orientation gauge valve
			X see data sheet 760.53		



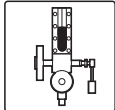

Sight glass level gauge CL150 to 600

Light execution
 Reflex, Transparent
 Connection top-bottom pivoted
 Connection gauge valve to gauge chamber: union
 Offset, quick closing

Product group **700**

Type **23**

Sheet: 1 Revision: 0

Date: 08/2011

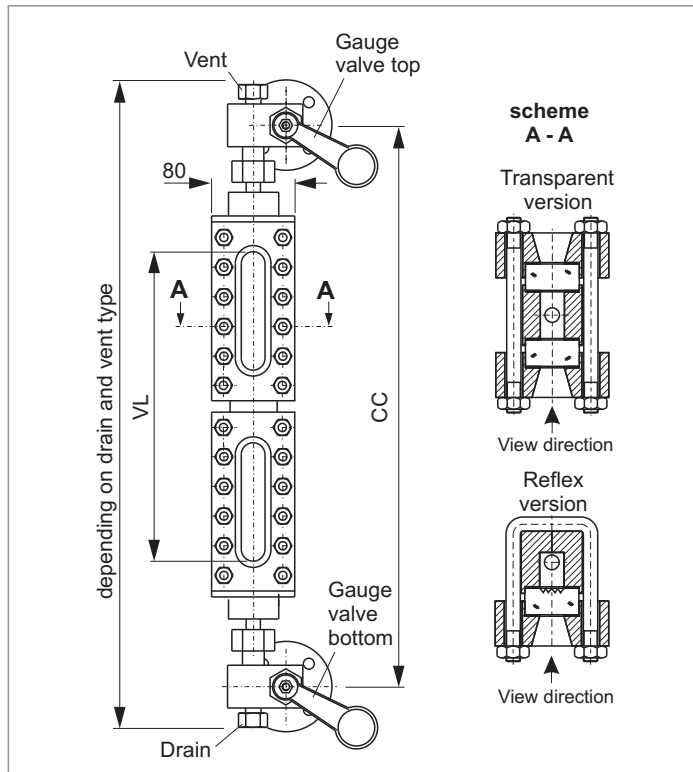

Field of Application

Direct reading liquid level indicator for general applications up to CL600 (depends on glass type). Increased safety with ball check valves.

General Data

Visible length VL: <CC
 Connection gauge valve - body: union
 Gauge valve types: see data sheet 760.58
 Actuation: quick closing
 Material glass plates acc. to DIN 7081: Borosilicate
 Material media wetted parts: CS, SS
 Depending on delivery situation material can vary.
 Types with special materials e. g. Hastelloy, Monel etc. are available.

Design Data

Derating depends on temperature and window size

Further Data

Connection gauge valve - body: see 700.VAR
 Process connection: see 700.VAR
 Vent: see 700.VAR
 Drain: see 700.VAR

Accessories

Glass protection etc.: see accessories
 Frosts protection: see accessories
 Illumination: see accessories
 Scale: see accessories
 Heating: see accessories

Orientation of gauge valve and operation

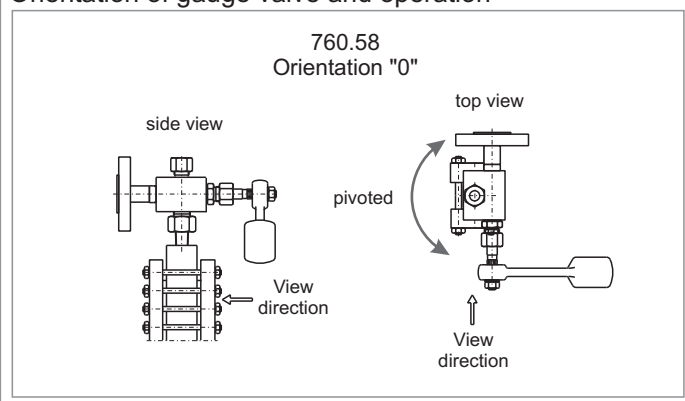

CS (= carbon steel) and SS (= stainless steel type 316SS) are materials suitable for Pressure Vessels according to EN or ASME.

Subject to alterations

Ordering no.

7 0 0 2 3 X X 5 8 0 X X - X X - X X X X X X X X X - X X X X		see 700.VAR	CC [mm]
bridging	without	0	results from ME
	with	1	X spec. glass types
glass window	Reflex (DIN 7081)	1	X X nos of segments
	Transparent (DIN 7081)	2	DIN-bolts, -nuts
gauge valve	760.58	5 8 0	A ANSI-bolts, -nuts
			X depends on design pressure
			see data sheet 760.58
			orientation gauge valve



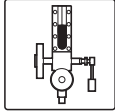

Sight glass level gauge CL600

Light execution
 Reflex, Transparent
 Connection top-bottom pivoted
 Connection gauge valve to gauge chamber: union
 Offset, quick closing

Product group **700**

Type **23XXA**

Sheet: 1 Revision: 0

Date: 08/2011

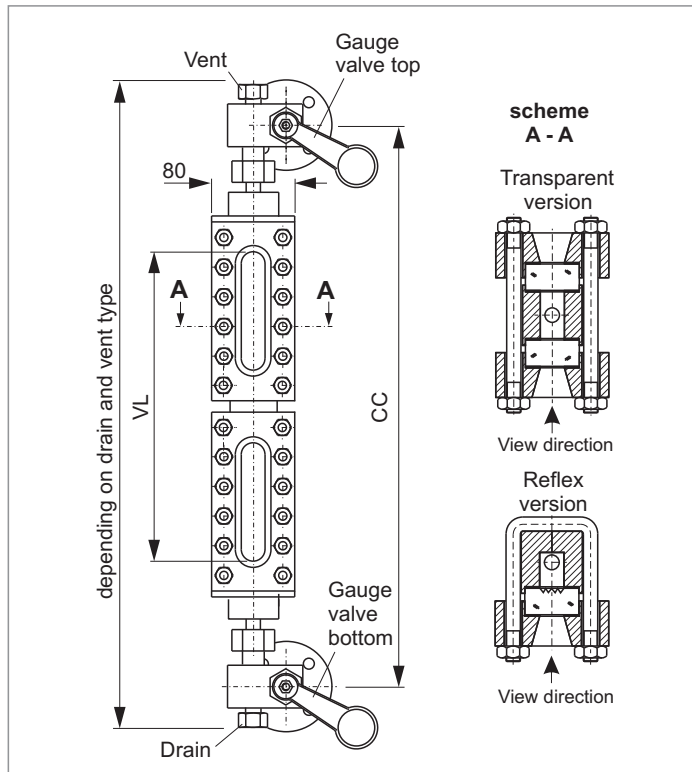

Field of Application

Direct reading liquid level indicator for general applications up to CL600 (depends on glass type). Increased safety with ball check valves.

General Data

Visible length VL: <CC
 Connection gauge valve - body: union
 Gauge valve types: see data sheet 760.58
 Actuation: quick closing
 Material glass plates acc. to DIN 7081: Borosilicate
 Material media wetted parts: CS, SS
 Depending on delivery situation material can vary.
 Types with special materials e. g. Hastelloy, Monel etc. are available.

Design Data

Derating depends on temperature and window size

Further Data

Connection gauge valve - body: see 700.VAR
 Process connection: see 700.VAR
 Vent: see 700.VAR
 Drain: see 700.VAR

Accessories

Glass protection etc.: see accessories
 Frosts protection: see accessories
 Illumination: see accessories
 Scale: see accessories
 Heating: see accessories

Orientation of gauge valve and operation

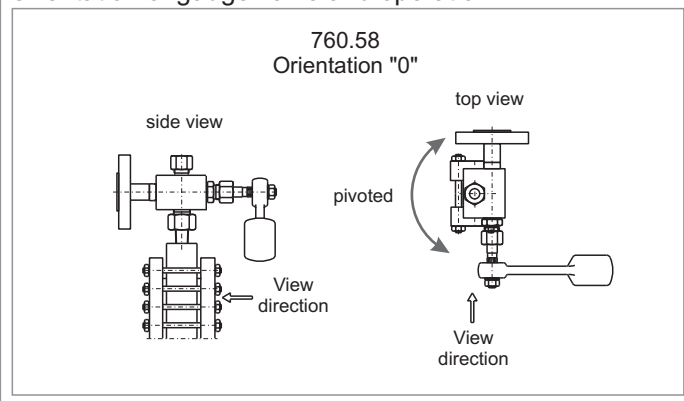

CS (= carbon steel) and SS (= stainless steel type 316SS) are materials suitable for Pressure Vessels according to EN or ASME.

Subject to alterations

Ordering no.

7 0 0 2 1 X X A 5 8 X X X - X X - X X X X X X X X X - X X X X			see 700.VAR	ME [mm]
bridging	without	0	X X nos of segments	results from ME
	with	1		X spec. glass types
glass window	Reflex (DIN 7081)	1	A ANSI-bolts, -nuts	DIN/ASME
	Transparent (DIN 7081)	2		X depends on design pressure
gauge valve	760.58	5 3	X see data sheet 760.58	orientation gauge valve



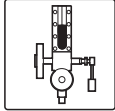

Sight glass level gauge CL600 bis 1500

"Cold" High pressure
 Reflex, Transparent
 Connection side-side fixed
 Connection gauge valve to gauge chamber: union
 Handwheel

Product group **700**

Type **26**

Sheet: 1

Revision: 0

Date:

08/2011

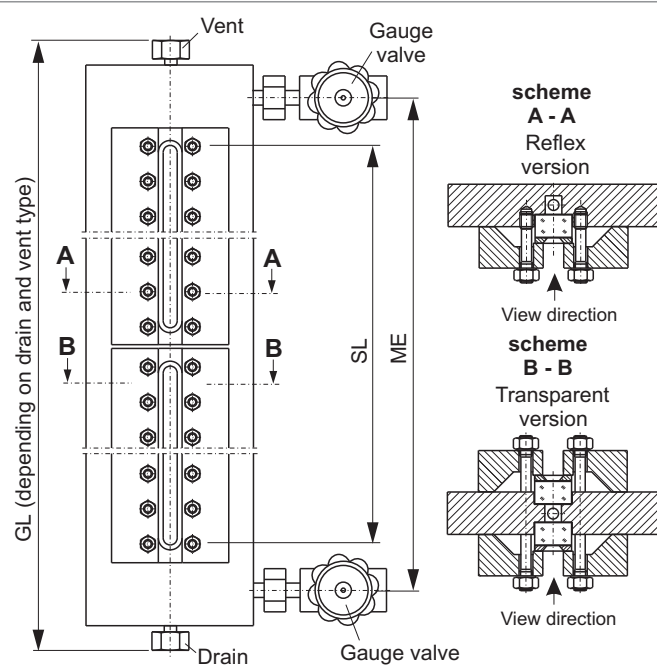

Field of Application

Direct reading liquid level indicator for general applications up to CL1500 (depends on glass type). Increased safety with ball check valves.

General Data

Visible length SL: \leq ME
 Connection gauge valve - body: union
 Gauge valve types: see data sheet 760.51/52
 Actuation: hand wheel
 Material glass plates acc. to DIN 7081: Borosilicate
 Material media wetted parts: CS, SS
 Depending on delivery situation material can vary.
 Types with special materials e. g. Hastelloy, Monel etc. are available.

Design Data

Derating depends on temperature and window size

Further Data

Connection gauge valve - body: see 700.VAR
 Process connection: see 700.VAR
 Vent: see 700.VAR
 Drain: see 700.VAR

Accessories

Glass protection etc.: see accessories
 Frosts protection: see accessories
 Illumination: see accessories
 Scale: see accessories
 Heating: see accessories

Orientation of gauge valve and operation

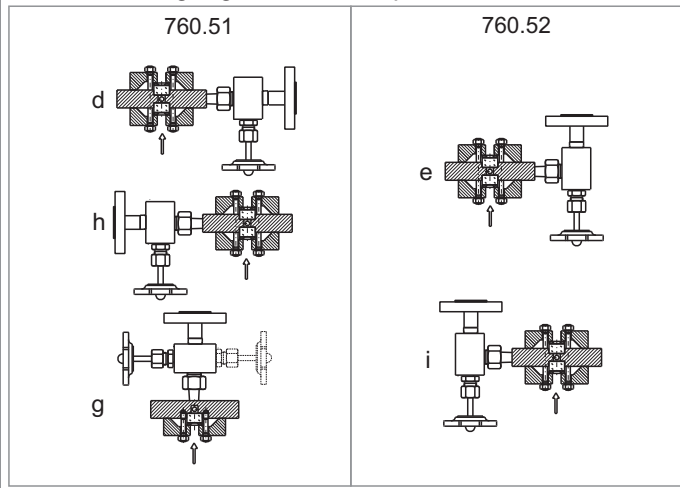

CS (= carbon steel) and SS (= stainless steel type 316SS) are materials suitable for Pressure Vessels according to EN or ASME.

Subject to alterations

Ordering no.

7 0 0 2 6 X X X X X X X X - X X - X X X X X X X X X X - X X X X X		see 700.VAR	ME [mm]
bridging	without	0	results from ME
	with	1	
glass window	Reflex (DIN 7081)	1	nos of segments
	Transparent (DIN 7081)	2	
gauge valve	760.51	5 1	DIN-bolts, -nuts
	760.52	5 2	A ANSI-bolts, -nuts
		X	X depends on design pressure
			siehe Datenblatt 760.51/52
			glass type
			DIN/ASME
			gauge body
			orientation
			gauge valve



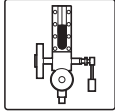

Sight glass level gauge CL600 bis 1500

"Cold" High pressure
 Reflex, Transparent
 Connection top-bottom pivoted
 Connection gauge valve to gauge chamber: union
 Offset, handwheel

Product group **700**

Type **27**

Sheet: 1 Revision: 0

Date: 08/2011

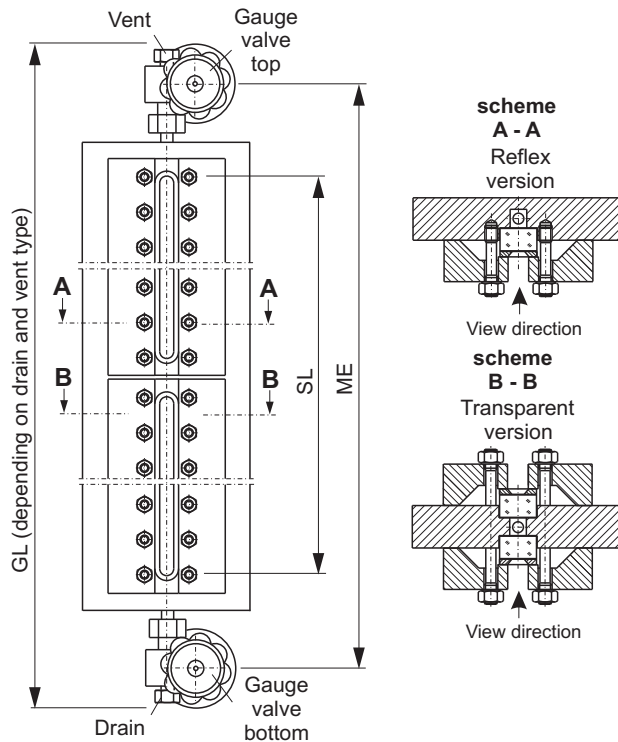

Field of Application

Direct reading liquid level indicator for general applications up to CL1500 (depends on glass type). Increased safety with ball check valves.

General Data

Visible length SL: $\leq \text{ME} - 180 \text{ mm}$
 Connection gauge valve - body: union
 Gauge valve types: see data sheet 760.53
 Actuation: hand wheel
 Material glass plates acc. to DIN 7081: Borosilicate
 Material media wetted parts: CS, SS
 Depending on delivery situation material can vary.
 Types with special materials e. g. Hastelloy, Monel etc. are available.

Design Data

Derating depends on temperature and window size

Further Data

Connection gauge valve - body: see 700.VAR
 Process connection: see 700.VAR
 Vent: see 700.VAR
 Drain: see 700.VAR

Accessories

Glass protection etc.: see accessories
 Frosts protection: see accessories
 Illumination: see accessories
 Scale: see accessories
 Heating: see accessories

Orientation of gauge valve and operation

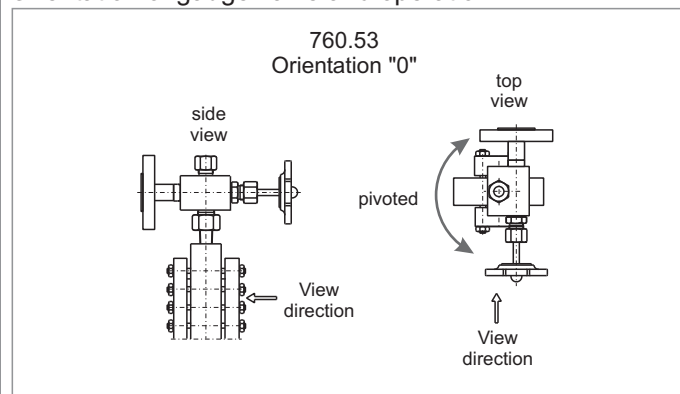

CS (= carbon steel) and SS (= stainless steel type 316SS) are materials suitable for Pressure Vessels according to EN or ASME.

Subject to alterations

Ordering no.

7 0 0 2 7 X X 5 3 X X X - X X - X X X X X X X X X - X X X X		see 700.VAR	ME [mm]
bridging	without	0	results from ME
	with	1	
glass window	Reflex (DIN 7081)	1	glass type
	Transparent (DIN 7081)	2	
gauge valve	760.53	5 3 X	DIN-bolts, -nuts
			A ANSI-bolts, -nuts
			X depends on design pressure
			DIN/ASME
			gauge body
			orientation
			gauge valve
			siehe Datenblatt 760.53



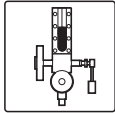

Sight Glass Level Gauge CL300

Connection top-bottom pivoted
 Reflex, transparent
 Gauge heads 760.51/52/53 optional

Product group **700**

Type **46**

Sheet: 1

Revision: 0

Date:

08/2011

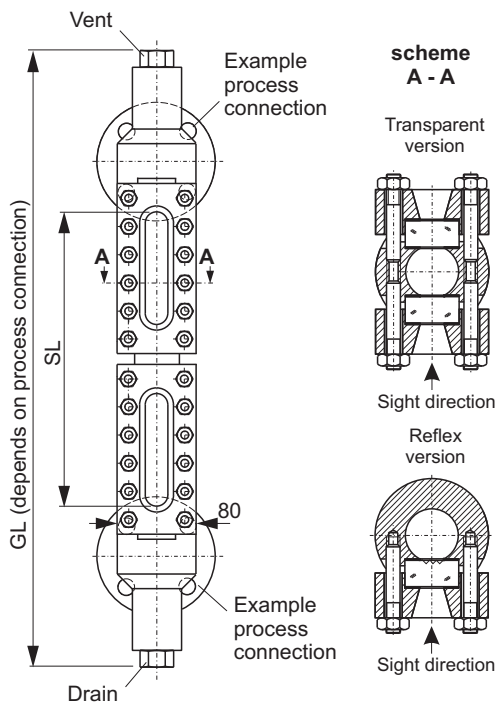

Field of Application

Direct reading liquid level indicator with glass tube for easily out-gassing media up to CL300 (depends on glass type).

General Data

Visible length SL: <GL
 Process connection: flange, nipple
 Material glass plates: Borosilicate
 Material media wetted parts: CS, SS
 Depending on delivery situation material can vary.
 Types with special materials e. g. Hastelloy, Monel etc. are available.

Design Data

Derating depends on temperature and window size

Further Data

Process connection: see 700.VAR

Accessories

Glass protection etc.: see accessories catalogue 700
 Frosts protection: see accessories catalogue 700
 Illumination: see accessories catalogue 700
 Scale: see accessories catalogue 700
 Heating: see accessories catalogue 700

Examples connection

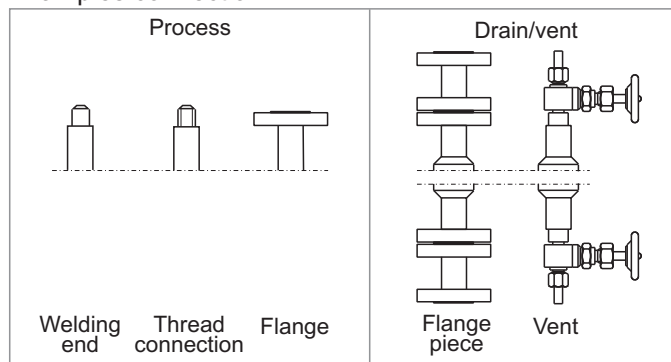

CS (= carbon steel) and SS (= stainless steel type 316SS) are materials suitable for Pressure Vessels according to EN or ASME.

Subject to alterations

Ordering no.

7 0 0 4 6 X 2 0 0 0 0 X - X X - X X X X X X X X X X - X X X X X
see 700.VAR ME [mm]

bridging	without	0	X X nos of segments	results from SL	glass type
	with	1		X spec. glass types	
			DIN-bolts, -nuts		DIN/ASME
			A ANSI-bolts, -nuts		



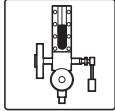

Sight Glass Level Gauge weld-in CL600

Reflex, transparent
 Body open, closed

Product group **700**

Type **31/32**

Sheet: 1

Revision: 0

Date:

08/2011



Type 700.31

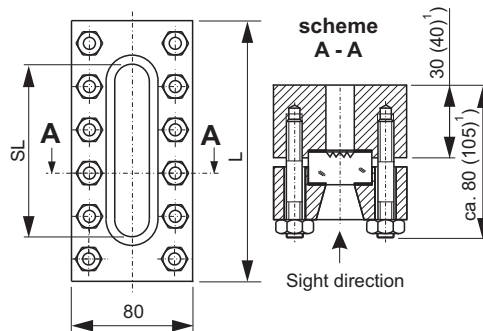

¹⁾ with larger pressures, tank volumes or lengths

Type 700.32

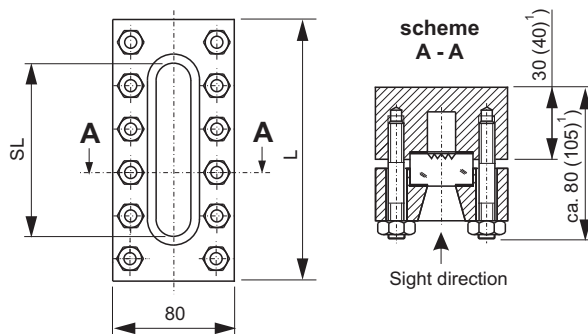

¹⁾ with larger pressures, tank volumes or lengths

Measures in mm

Dimension table

Glass size	length L	sight length SL	Glass size	length L	sight length SL
0	118	75	11	423	380
1	138	95	12	453	410
2	163	120	13	483	440
3	188	145	14	523	480
4	213	170	15	553	510
5	243	200	16	583	540
6	273	230	17	623	580
7	303	260	18	653	610
8	343	300	19	683	640
9	363	320	20	723	680
10	393	350			

Field of Application

Direct reading liquid level indicator for welding in a container wall, up to CL600.

General Data

Body: weld-in
 optionally corners rounded
 Process connection: welded
 Material glass plates DIN 7081: Borosilicate
 Material media wetted parts: CS, SS
 Types with special materials e. g. Hastelloy, Monel etc. are available.

Design Data

Derating depends on temperature and window size

Accessories

Glass protection etc.: see accessories catalogue 700

CS (= carbon steel) and SS (= stainless steel type 316SS) are materials suitable for Pressure Vessels according to EN or ASME.

Subject to alterations

Ordering no.

7 0 0 3 X 1 X X X

Body	open	1	X X glass size	Glass size e. g. 08=glass size 8
	closed	2	1 reflex	Sight glass
			2 transparent	



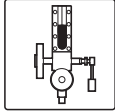

Reflection Water Level Gauge PN CL300

Reflection
 Connection side-side fixed
 Gauge heads integrated
 Glass holder: side plates, hinged
 Handwheel

equivalent to Vaihinger 22/2000

Product group **700**

Type **B1**

Sheet: 1 Revision: 0

Date: 08/2011



Type 700.B1

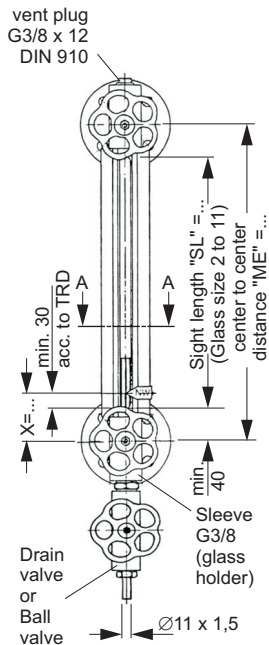
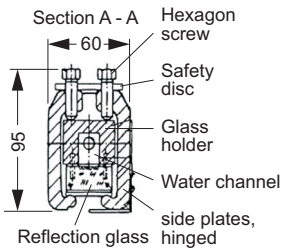

Measures in mm

Arrangement

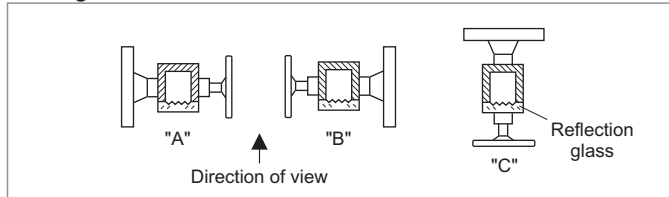

Glass size / range of centre-to-centre-distance

glass size	2	3	4	5	6	7	8	9	10	11
glass length / mm	140	165	190	220	250	280	320	340	370	400
"SL" per segment	120	145	170	200	230	260	300	320	350	380
min. centre-to-centre-distance / mm										
1 x glass size	200	225	250	280	310	340	380	400	430	460
2 x glass size	370	420	470	530	590	650	730	770	830	890
3 x glass size	540	615	690	780	870	960	1080	1140	1230	1320

Field of Application

The liquid water level gauge type 700.B1 is a reflection gauge for direct reading water level in steam boilers. They are equipped with sight glasses with grooves for a clear contrast in the display.

General Data

Sight length SL *): <ME
 Glass size **): 2 - 11 (34 x 17 mm)
 Actuation: handwheel
 Connection gauge head - body: valves integrated
 Valve passage: 8 mm
 Process connection: flange DIN, EN or ANSI
 Materials
 - Sight glasses DIN 7081: Borosilikate
 - Glass holder: CS
 - Connection flanges: CS
 - Shut off parts: SS
 - Gaskets: Graphite

Design Data

Design temperature / Design pressure: -10 ...100 °C / 40 bar
 up to 200 °C / 32 bar
 up to 243 °C / 30 bar

Accessories

Pointer: NW-mark acc. to TRD
 for shut-off valves: automatically closing ball (safety device) (at least 1 bar pressure tanks required for the function)
 Glass protection: Mica exterior protection

*) Sight length "SL" = min. center-center-distance
 "ME" - 80

Interruption between 2 sight glasses: min. 50

**) Other glass sizes available on request

CS (= carbon steel) are suitable pressure vessel steels according to EN or ASME.

Änderungen vorbehalten

Ordering no.

see 700.VAR ME / mm SL / mm
 7 0 0 B 1 0 1 X - - - - - - - - - X X X X X - X X X X X

Arrangement	"A"	A
	"B"	B
	"C"	C



ING. ROLF HEUN
 Mess- Prüf- Regeltechnik GmbH

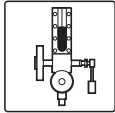

Reflection Water Level Gauge PN 40

Reflection
 Connection side-side fixed
 Gauge heads side - side
 Glass holder: side plates, hinged
 Lever

equivalent to Vaihinger 17/202

Product group **700**

Type **B5**

Sheet: 1 Revision: 0

Date: 08/2011

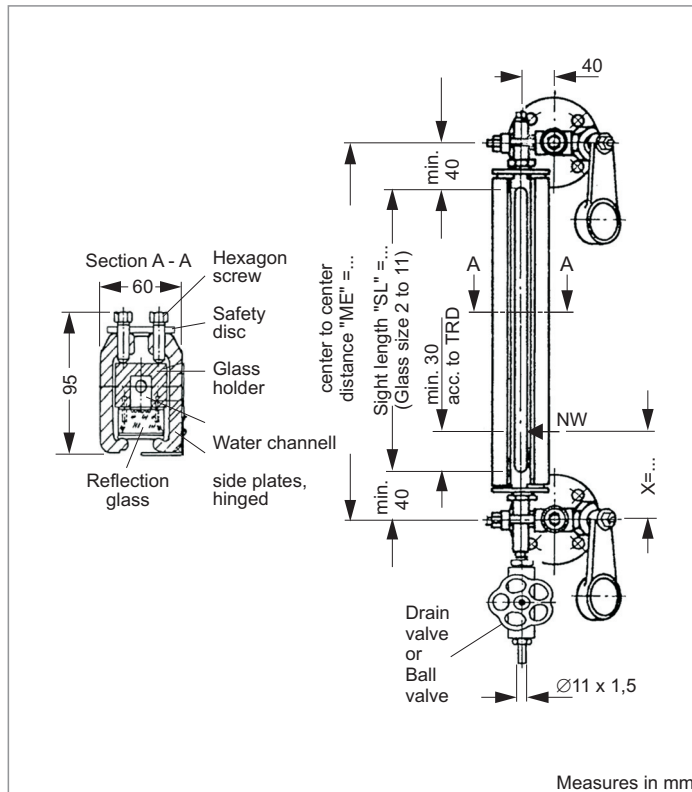

Field of Application

The water level gauge type 700.B5 is a reflection gauge for direct reading water level in steam boilers. They are equipped with sight glasses with grooves for a clear contrast in the display.

General Data

Sight length SL *): <ME
 Glass size **): 2 - 11 (34 x 17 mm)
 Actuation: lever
 Connection gauge head - body: valves side - side
 Valve type: 760.11
 Valve passage: 8 mm
 Process connection: flange DIN, EN or ANSI
 Materials
 - Sight glasses DIN 7081: Borosilikate
 - Glass holder: CS
 - Connection flanges: CS
 - Shut off parts: SS
 - Gaskets: Graphite

Design Data

Design temperature / Design pressure: -10 ... 100 °C / 40 bar
 up to 200 °C / 32 bar
 up to 243 °C / 30 bar

Accessories

Pointer: NW-mark acc. to TRD
 for shut-off valves: automatically closing ball (safety device)
 (at least 1 bar pressure tanks required for the function)
 Glass protection: Mica exterior protection

Arrangement

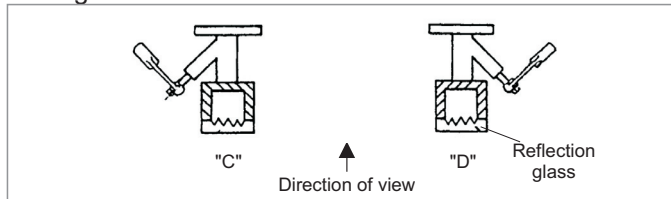

Glass size / range of center-to-center-distance

glass size	2	3	4	5	6	7	8	9	10	11
glass length / mm	140	165	190	220	250	280	320	340	370	400
"SL" per segment	120	145	170	200	230	260	300	320	350	380
min. centre-to-centre-distance / mm										
1 x glass size	200	225	250	280	310	340	380	400	430	460
2 x glass size	370	420	470	530	590	650	730	770	830	890
3 x glass size	540	615	690	780	870	960	1080	1140	1230	1320

*) Sight length "SL" = min. center-center-distance
 "ME" - 80
 Interruption between 2 sight glasses: min. 50
 **) Other glass sizes available on request

CS (= carbon steel) are suitable pressure vessel steels according to EN or ASME.

subject to alterations

Ordering no.

see 700.VAR ME / mm SL / mm

7 0 0 B 5 0 1 X - - - - - - - - - - X X X X - X X X X

Arrangement	"C"	C
	"D"	D



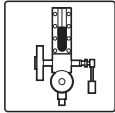

Reflection Water Level Gauge PN 40		Product group	700
Reflection Connection side-side fixed Gauge heads side - side Glass holder rotatable with pressure frame Lever		Type	B6
equivalent to Vaihinger 17/202L		Sheet: 1	Revision: 0
		Date:	10/2012

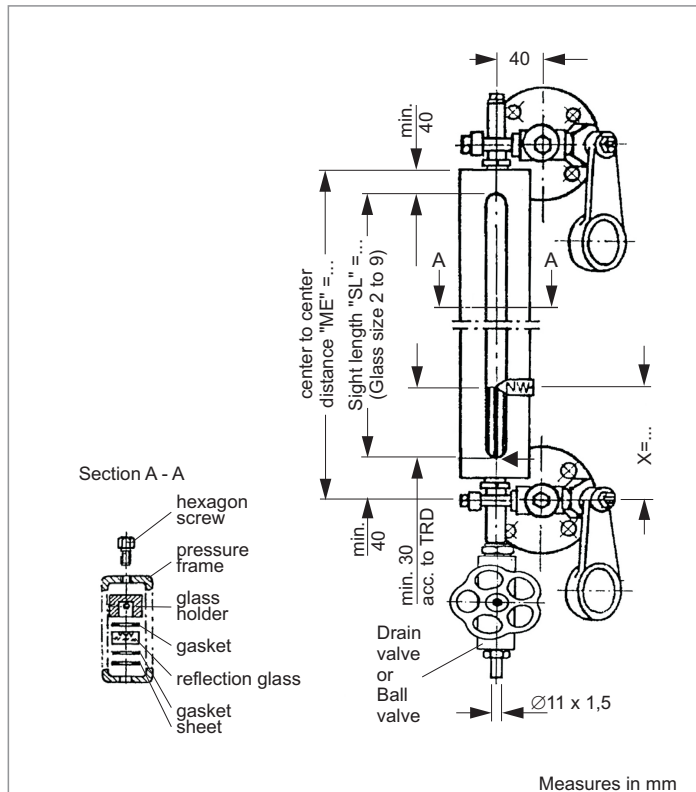

Field of Application

The water level gauge type 700.B6 is a reflection gauge for direct reading water level in steam boilers. They are equipped with sight glasses with grooves for a clear contrast in the display.

General Data

- Sight length SL *): <ME
- Glass size **): 2 - 9 (34 x 17 mm)
- Actuation: lever
- Connection gauge head - body: valves side - side
- Valve type: 760.11
- Valve passage: 8 mm
- Process connection: flange DIN, EN or ANSI
- Materials
- Sight glasses DIN 7081: Borosilikate
- Glass holder: CS
- Connection flanges: CS
- Shut off parts: SS
- Gaskets: Graphite

Design Data

- Design temperature / -10 ... 100 °C / 40 bar
- Design pressure: up to 200 °C / 32 bar
- max. limit for reflection glass DIN 7081 = 243 °C

Accessories

- Pointer: NW-mark acc. to TRD
- for shut-off valves: automatically closing ball (safety device)
- (at least 1 bar pressure tanks required for the function)
- Mica exterior protection

Arrangement

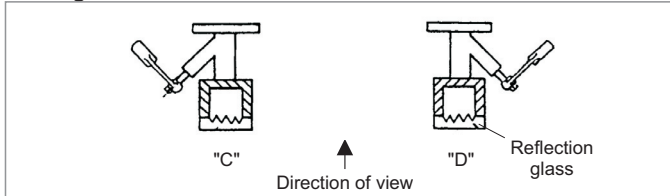

Glass size / range of center-to-center-distance

glass size	2	3	4	5	6	7	8	9		
glass length / mm	140	165	190	220	250	280	320	340		
"SL" per segment	120	145	170	200	230	260	300	320		
min. centre-to-centre-distance / mm										
1 x glass size	200	225	250	280	310	340	380	400		
2 x glass size				520	580	640	720	760		

- *) Sight length "SL" = min. center-center-distance "ME" - 80
- Interruption between 2 sight glasses: min. 40
- **) Other glass sizes available on request

CS (= carbon steel) are suitable pressure vessel steels according to EN or ASME.

subject to alterations

Ordering no.

see 700.VAR ME / mm SL / mm

7 0 0 B 6 0 1 X - - - - - - - - - - X X X X - X X X X

Arrangement	"C"	C
	"D"	D



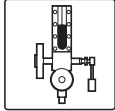

Reflection Water Level Gauge PN 40

Reflection
 Connection back-side
 Gauge heads side - side, pivots
 Glass holder: side plates, hinged
 Lever

equivalent to Vaihinger 17/215

Product group **700**

Type **B7**

Sheet: 1 Revision: 0

Date: 08/2011

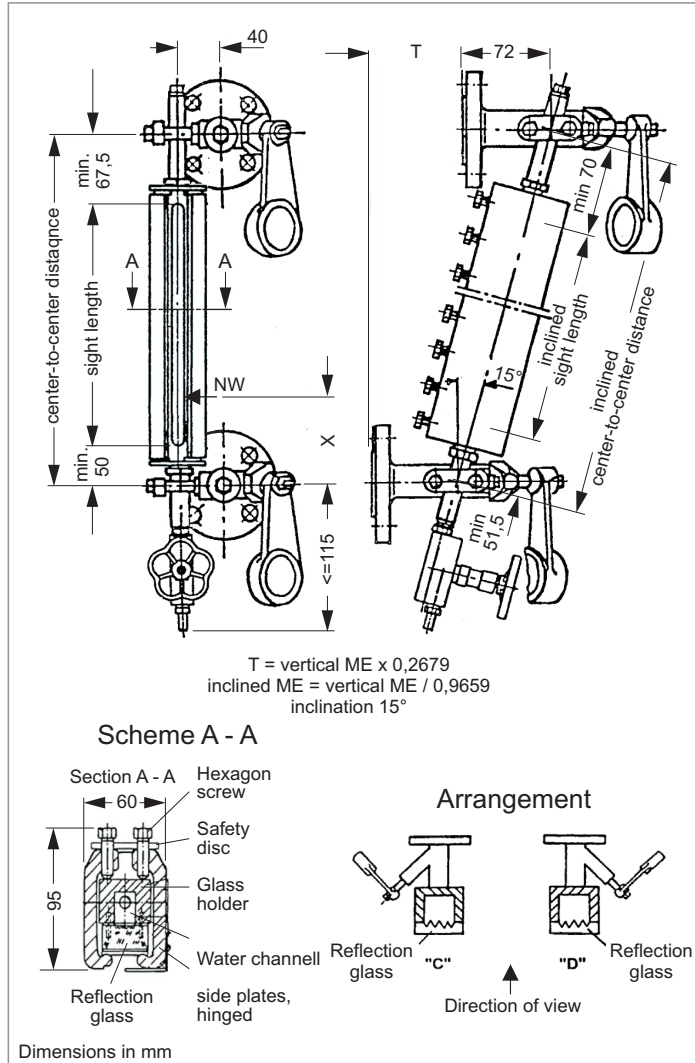

Dimensions in mm

Glass size / range of center-to-center-distance

glass size	2	3	4	5	6	7	8	9
glass length / mm	140	165	190	220	250	280	320	340
"SL" per Segment	120	145	170	200	230	260	300	320
vertical CCD** from	233,5	257,5	281,5	310,5	339,5	368,5	407	426,5
to	265	290	320	345	375	415	435	465

Field of Application

The water level gauge type 700.B7 is a universal reflection gauge for direct reading e. g. for storage vessels. They are equipped with sight glasses with grooves for a clear contrast in the display.

General Data

Sight length SL *): <ME lever
 Actuation: lever
 Connection gauge head - glass holder: valves side - side
 Valve type: 760.11
 Valve passage: 8 mm
 Process connection: flange DIN, EN or ANSI
 Vent plug: M12x12 - DIN 910
 Materials: Borosilikate
 - Sight glasses DIN 7081: CS
 - Glass holder: CS
 - Connection flanges: CS
 - Shut off parts: CS
 - Gaskets: Graphite

Design Data

Design temperature / Design pressure: -10 ...120 °C / 40 bar
 -10 ...238 °C / 32 bar

Accessories

Pointer: NW-mark acc. to TRD
 for shut-off valves: automatically closing ball (safety device)
 (at least 1 bar pressure tanks required for the function)
 Mica exterior protection

Glass protection:

CS (= carbon steel) are suitable pressure vessel steels according to EN or ASME.

subject to alterations

Ordering no.

see 700.VAR CCD / mm SL / mm
 7 0 0 B 7 0 1 X - - - - - - - - - X X X X X - X X X X X

Arrangement	"C"	C
	"D"	D



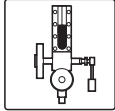

Transparent Sight Glass Level Gauge PN 40

Transparent
 Connection back-side
 Gauge heads integrated
 Glass holder with smooth sight glasses
 Handwheel

equivalent to Vaihinger 22/230DG-N

Product group **700**

Type **C0**

Sheet: 1 Revision: 1

Date: 11/2011

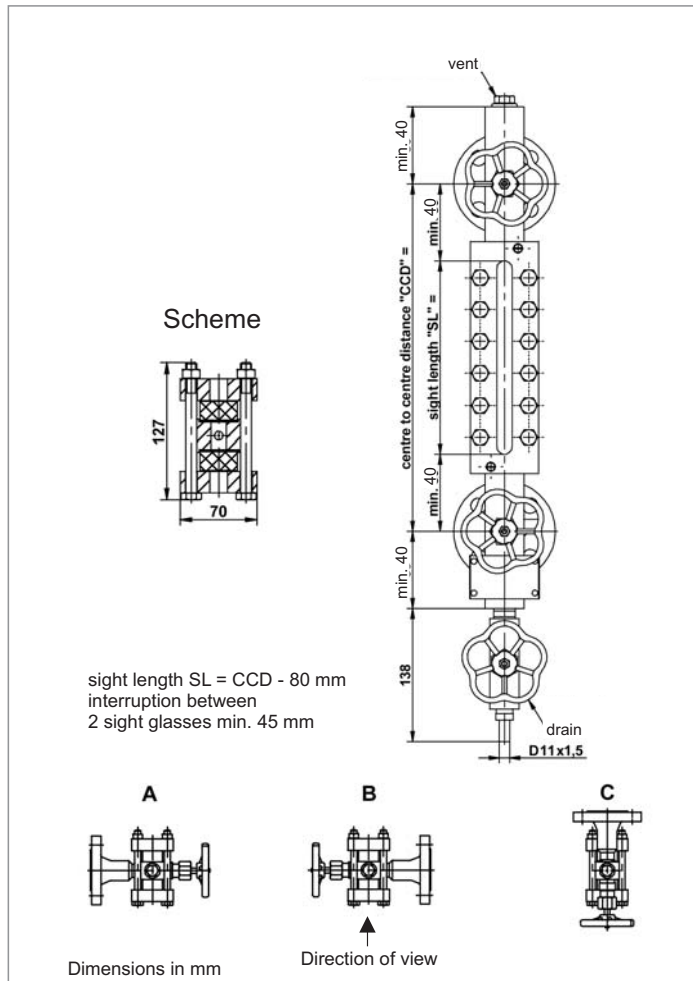

Glass size / range of centre-to-centre-distance

glass size	2	3	4	5	6	7	8	9
glass length / mm	140	165	190	220	250	280	320	340
"SL" per Segment	120	145	170	200	230	260	300	320
min. CCD / mm								
1 x glass size	200	225	250	280	310	340	380	400
2 x glass size	365	415	465	525	585	645	725	765
3 x glass size	530	605	680	770	860	950	1070	1130
4 x glass size	695	795	895	1015	1135	1255	1415	1495
5 x glass size	860	985	1110	1260	1410	1560	1760	1860

Field of Application

The transparent sight glass level gauge type 700.C0 is for direct reading e. g. for storage vessels.

General Data

Sight length SL *): <ME
 Actuation: handwheel
 Connection gauge head - body: valves integrated
 Valve passage: 8 mm
 Process connection: flange DIN, EN or ANSI
 Materials
 - Sight glasses DIN 7081: Borosilikate
 - Glass holder: CS
 - Connection flanges: CS
 - Drain valve: CS
 - Shut off parts: SS
 - Gaskets: graphite

Design Data

Design temperature / -10 ... 120 °C / 40 bar
 Design pressure: -10 ... 200 °C / 35 bar
 (for glass size 2 to 9): -10 ... 243 °C / 32 bar
 -10 ... 300 °C *) / 30 bar

*) with mica protection inner side

Accessories

Pointer: NW-mark acc. to TRD
 for shut-off valves: automatically closing ball (safety device) (at least 1 bar pressure tanks required for the function)
 Glass protection: Mica exterior protection
 illumination device series: see 709

CS (= carbon steel) is a steel according to EN or ASME.

subject to alterations

Ordering no.

see 700.VAR CCD / mm SL / mm

7 0 0 C 0 0 2 X - - X - - - - - - - X X X X - X X X X

Arrangement	"C"	C
	"D"	D
Glass protection	without	0
	Mica outside	I



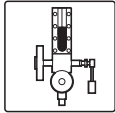

Transparent Sight Glass Level Gauge PN 63

Transparent
 Connection back-side
 Gauge heads backside
 Glass holder with smooth sight glasses
 Lever
equivalent to Vaihinger 68/40DG PN63

Product group **700**

Type **C4**

Sheet: 1 Revision: 1

Date: 11/2011

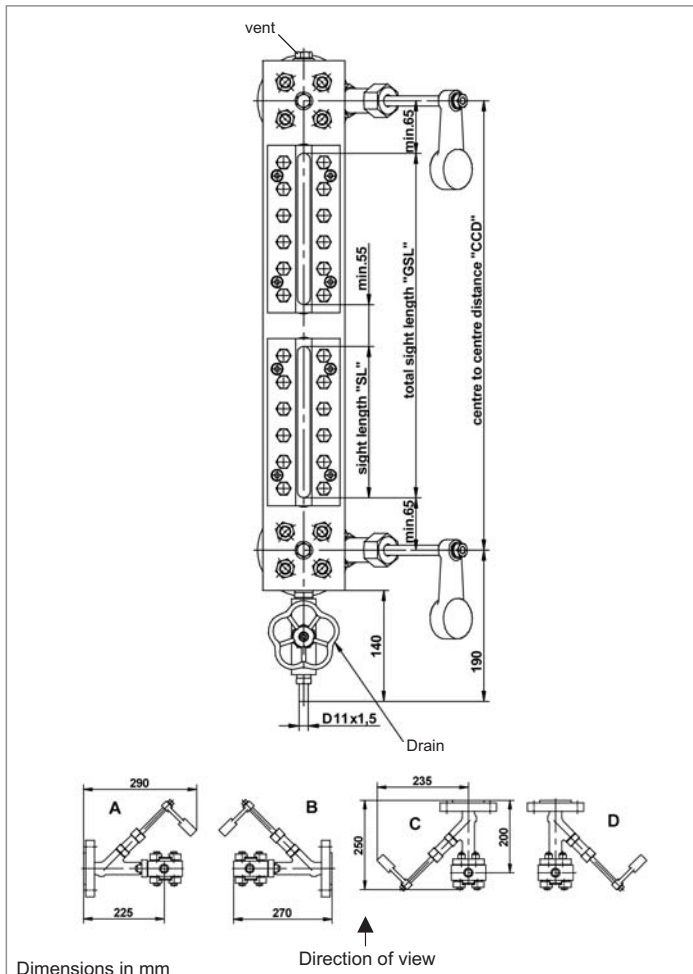

Dimensions in mm

Direction of view

Glass size / range of centre-to-centre-distance

glass size	5	6	7	8	9
glass length / mm	220	250	280	320	340
"SL" per segment	200	230	260	300	320
min. CCD / mm					
1 x glass size	330	360	390	430	450
2 x glass size	585	645	705	785	825
3 x glass size	840	930	1020	1140	1200
4 x glass size	1095	1215	1335	1495	1575
5 x glass size	1350	1500	1650	1850	1950

Field of Application

The transparent sight glass level gauge type 700.C4 is for direct reading e. g. for storage vessels.

General Data

Sight length SL *): <ME *)
 Actuation: lever
 Connection gauge head - body: valves backside
 Valve type: 760.68
 Valve passage: 8 mm
 Process connection: flange DIN, EN or ANSI
 Materials: CS, SS
 Material sight glasses DIN 7081: Borosilikate
 Material gaskets: graphite
 Other materials on request.

Design Data

Design temperature/ -10 ... 120 °C / 63 bar
 Design pressure -10 ... 200 °C / 50 bar
 (for glass size 2 to 9): -10 ... 243 °C / 45 bar
 -10 ... 300 °C *) / 40 bar

*) with mica protection inner side

Accessories

Pointer: NW-mark acc. to TRD
 for shut-off valves: automatically closing ball (safety device)
 (at least 1 bar pressure tanks required for the function)
 Glass protection: Mica exterior protection
 illumination device series: see 709

Sight length SL = min. CCD - 130 mm.

*) design „centre-to-centre distance = sight length“ only arrangement A + B.

Interruption between 2 sight glasses: min. 55 mm.
 Valves with stuffing box enlarged version easy for outgassing fluids.

CS (= carbon steel) and SS (= stainless steel) are suitable pressure vessel steels according to EN or ASME.

subject to alterations

Ordering no.

siehe 700.VAR ME / mm SL / mm
 7 0 0 C 4 0 2 X - - - - - - - - - - X X X X X - X X X X X

Arrangement	"A"	A
	"B"	B
	"C"	C
	"D"	D



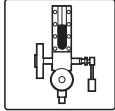

Transparent Sight Glass Level Gauge PN 100 Transparent Connection back-side Gauge heads backside Glass holder with smooth sight glasses Lever <div style="text-align: right; font-size: small;"><i>equivalent to Vaihinger 68/40DG PN100</i></div>	Product group 700				
	Type C5				
	<table border="1" style="width: 100%; border-collapse: collapse;"> <tr> <td style="width: 50%; padding: 2px;">Sheet: 1</td> <td style="width: 50%; padding: 2px;">Revision: 1</td> </tr> <tr> <td style="padding: 2px;">Date:</td> <td style="padding: 2px;">11/2011</td> </tr> </table>	Sheet: 1	Revision: 1	Date:	11/2011
	Sheet: 1	Revision: 1			
Date:	11/2011				

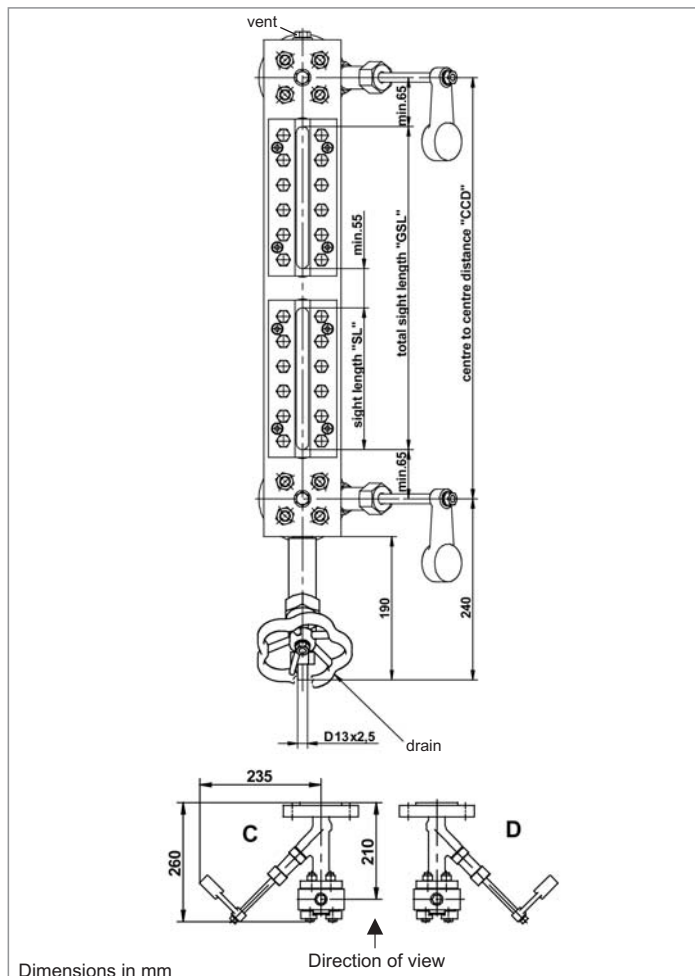

Dimensions in mm

Direction of view

Glass size / range of centre-to-centre-distance

glass size	5	6	7	8	9
glass length / mm	220	250	280	320	340
"SL" per segment	200	230	260	300	320
	min. CCD / mm				
1 x glass size	330	360	390	430	450
2 x glass size	585	645	705	785	825
3 x glass size	840	930	1020	1140	1200
4 x glass size	1095	1215	1335	1495	1575
5 x glass size	1350	1500	1650	1850	1950

Field of Application

The transparent sight glass level gauge type 700.C4 is for direct reading e. g. for storage vessels.

General Data

Sight length SL *): <ME *)
 Actuation: lever
 Connection gauge head - body: valves backside
 Valve type: 760.68
 Valve passage: 8 mm
 Process connection: flange DIN, EN or ANSI
 Materials: CS, SS
 Material sight glasses DIN 7081: Borosilikate
 Material gaskets: graphite
 Other materials on request.

Design Data

Design temperature/ -10 ... 120 °C / 100 bar
 Design pressure -10 ... 200 °C / 90 bar
 (for glass size 2 to 9): -10 ... 300 °C *) / 82 bar

*) with mica protection inner side

Accessories

Pointer: NW-mark acc. to TRD
 for shut-off valves: automatically closing ball (safety device)
 (at least 1 bar pressure tanks required for the function)
 Glass protection: Mica exterior protection
 illumination device series: see 709

Sight length SL = min. CCD - 130 mm.

*) design „centre-to-centre distance = sight length“
 Interruption between 2 sight glasses: min. 55 mm.

CS (= carbon steel) and SS (= stainless steel) are suitable pressure vessel steels according to EN or ASME.

subject to alterations

Ordering no.

siehe 700.VAR ME / mm SL / mm

7 0 0 C 4 0 2 X - - - - - - - - - - X X X X - X X X X

Arrange- ment	"C"	C
	"D"	D



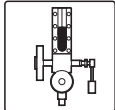

Transparent Sight Glass Level Gauge PN 100

Red - green
 Connection back-side
 Gauge heads backside
 Glass holder with smooth sight glasses
 Lever

equivalent to Vaihinger 68/40DF

Product group **700**

Type **C7**

Sheet: 1 Revision: 0

Date: 08/2011

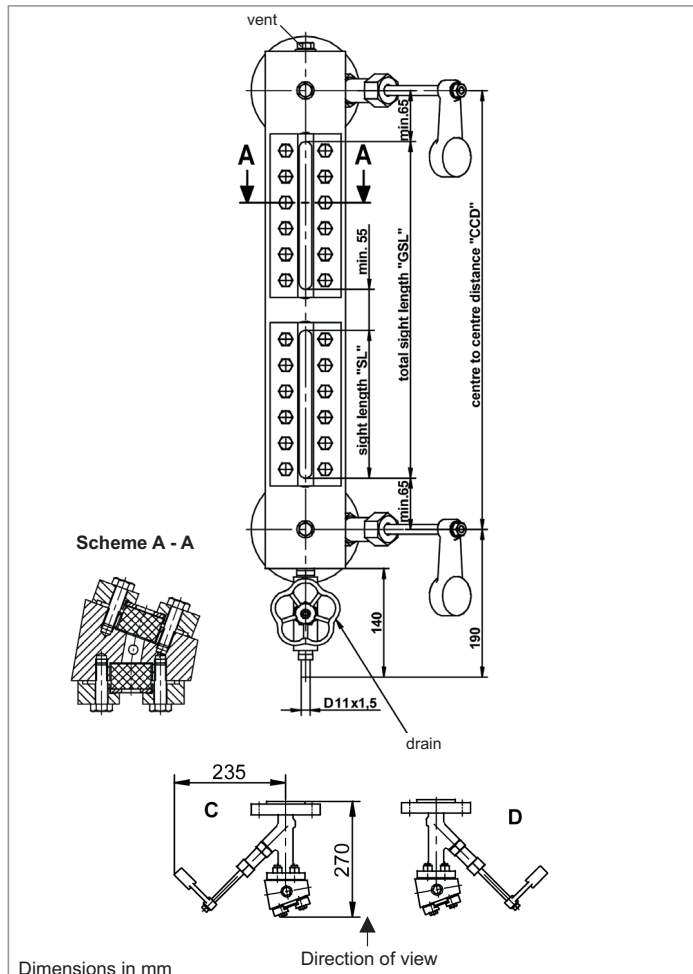

Dimensions in mm

Glass size / range of centre-to-centre-distance

glass size	5	6	7	8	9
glass length / mm	220	250	280	320	340
"SL" per segment	200	230	260	300	320
min. CCD / mm					
1 x glass size	330	360	390	430	450
2 x glass size	585	645	705	785	825
3 x glass size	840	930	1020	1140	1200
4 x glass size	1095	1215	1335	1495	1575
5 x glass size	1350	1500	1650	1850	1950

Field of Application

The transparent sight glass level gauge type 700.C7 is for direct reading e. g. for steam boilers.

General Data

Sight length SL *): <ME *)
 Actuation: lever
 Connection gauge head - body: valves backside
 Valve type: 760.68
 Valve passage: 8 mm
 Process connection: flange DIN, EN or ANSI
 Materials: CS
 Material sight glasses DIN 7081: Borosilikate
 Material gaskets: graphite
 Other materials on request.

Design Data

Design temperature/ -10 ... 120 °C / 70 bar
 Design pressure -10 ... 200 °C / 65 bar
 (up to glass size 7): -10 ... 243 °C / 55 bar
 -10 ... 300 °C *) / 45 bar

*) with mica protection inner side

Accessories

Pointer: NW-mark acc. to TRD
 for shut-off valves: automatically closing ball (safety device)
 (at least 1 bar pressure tanks required for the function)
 Glass protection: Mica exterior protection
 illumination device series: see 709

Sight length SL = min. CCD - 130 mm.
 Interruption between 2 sight glasses: min. 55 mm.

CS (= carbon steel) are suitable pressure vessel steels according to EN or ASME.

subject to alterations

Ordering no.

siehe 700.VAR ME / mm SL / mm

7 0 0 C 7 0 2 X - - - - - - - - - - X X X X - X X X X

Arrangement	"C"	C
	"D"	D



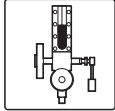

Liquid Level Gauge PN 160

Refraction
 Connection back-side
 double-shut-off valves side-side, with automatically closing ball
 Mica holder with mica sheets
 Lever

equivalent to Vaihinger 18/30 PN63/100

Product group **700**

Type **C8**

Sheet: 1 Revision: 1

Date: 11/2011

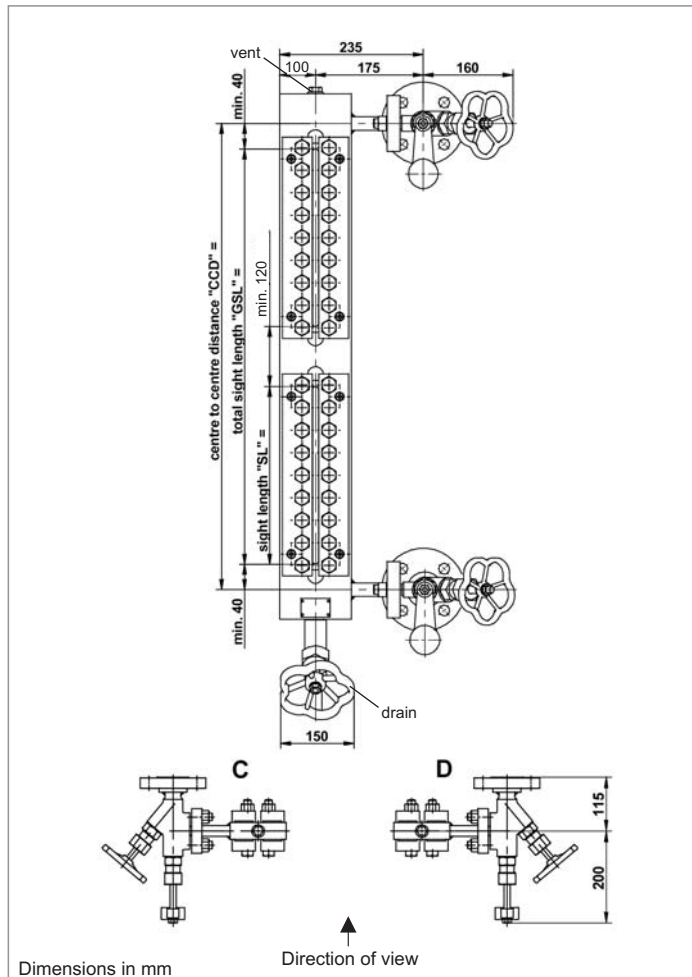

Dimensions in mm

Direction of view

Mica size / range of center-to-center-distance

Mica size	3	4	5	6	7	8	9
Mica length / mm	165	190	220	250	280	320	340
„SL“ per segment (mm)	145	170	200	230	260	300	320
min. center-to-center-distance (mm)							
1 x Mica size	225	250	280	310	340	380	400
2 x Mica size	490	540	600	660	720	800	840
3 x Mica size	755	830	920	1010	1100	1220	1280
4 x Mica size	1020	1120	1240	1360	1480	1640	1720
5 x Mica size	1285	1410	1560	1710	1860	2060	2160

Field of Application

The refraction liquid level gauge type 700.C8 with the special design of the water channel effects a brilliant dark-light contrast between water and steam space and is well suited for TV remote indication.

General Data

Sight length SL *): <ME *)
 Actuation: lever, hand wheel
 Connection gauge head - body: valves side-side
 Valve type: 760.18
 Valve passage: 8 mm
 Process connection: flange DIN, EN or ANSI
 Materials: CS
 Material mica package: mica
 Material gaskets: graphite
 Other materials on request.

Design Data

Derating depends on temperature and window size

Accessories

Pointer: NW-mark acc. to TRD
 illumination device series: see 709

Sight length SL = min. CCD - 80 mm.
 Interruption between 2 sight glasses
 min. 120 mm.

CS (= carbon steel) are suitable pressure vessel steels according to EN or ASME.

subject to alterations

Ordering no.

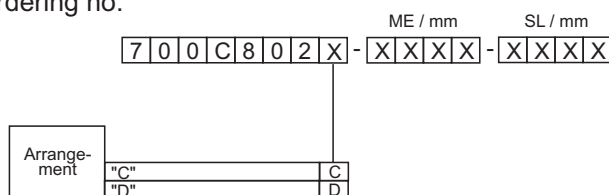

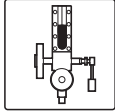

Liquid Level Gauge CL1500

Refraction
 Connection back-side
 double-shut-off valves side-side, with automatically closing ball
 Mica holder with mica sheets
 Lever

equivalent to Vaihinger 18/30 PN250

Product group **700**

Type **CA**

Sheet: 1 Revision: 1

Date: 11/2011

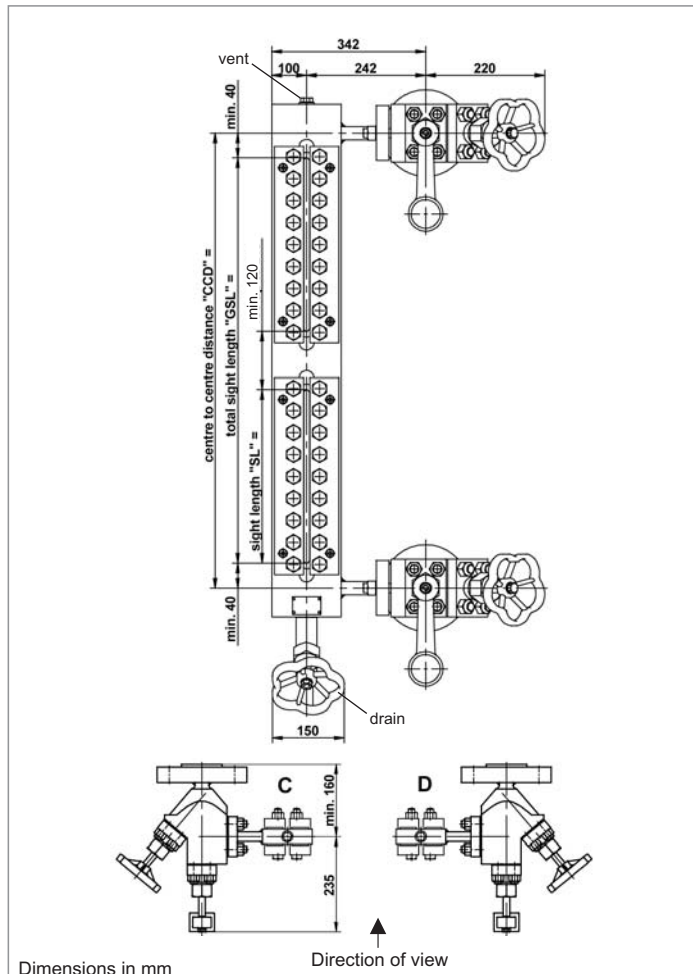

Dimensions in mm

Direction of view

Mica size / range of center-to-center-distance

Mica size	3	4	5	6	7	8	9
Mica length / mm	165	190	220	250	280	320	340
„SL“ per segment (mm)	145	170	200	230	260	300	320
min. center-to-center-distance (mm)							
1 x Mica size	225	250	280	310	340	380	400
2 x Mica size	490	540	600	660	720	800	840
3 x Mica size	755	830	920	1010	1100	1220	1280
4 x Mica size	1020	1120	1240	1360	1480	1640	1720
5 x Mica size	1285	1410	1560	1710	1860	2060	2160

Field of Application

The refraction liquid level gauge type 700.CA with the special design of the water channel effects a brilliant dark-light contrast between water and steam space and is well suited for TV remote indication.

General Data

Sight length SL *): <ME *)
 Actuation: lever, hand wheel
 Connection gauge head - body: valves side-side
 Valve type: 760.19
 Valve passage: 8 mm
 Process connection: flange DIN, EN or ANSI
 Materials: CS
 Material mica package: mica
 Material gaskets: graphite
 Other materials on request.

Design Data

Nominal pressure: CL1500
 Designtemperature/pressure max.: 374 °C / 165 bar

Accessories

Pointer: NW-mark acc. to TRD
 illumination device series: see 709

Sight length SL = min. CCD - 80 mm.
 Interruption between 2 segments
 min. 120 mm.

CS (= carbon steel) are suitable pressure vessel steels according to EN or ASME.

subject to alterations

Ordering no.

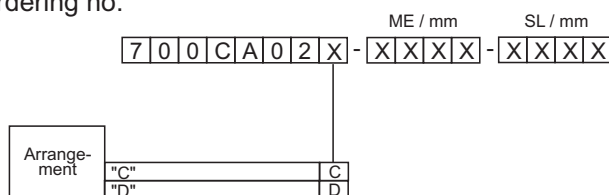

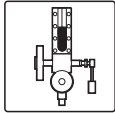

<h2 style="text-align: center;">Glass Tube Liquid Level Gauge PN 10</h2> <p>Connection top-bottom pivoted Handwheel Glass protection</p> <p style="text-align: right;"><i>equivalent to Vaihinger 16/14 PN10</i></p>	Product group 700
	Type A1
	Sheet: 1 Revision: 0
	Date: 08/2011

Field of Application

Direct reading liquid level indicator with glass tube for general applications up to CL150. Increased safety with ball check valves and glass protection.

General Data

Center-to-center CCD: max. 1200 mm
 Sight length: ME - 110 mm
 Diameter of glass tube *): Ø13,5 x 1,75 mm)
 Actuation: handwheel
 Valve passage: 8 mm
 Process connection: male thread G1/2
 DIN ISO 228
 flange DN15-25/PN10

Materials

- gauge heads: steel 1.0570/1.0460
 - gaskets for glass tube: PTFE
 - glass tube: DURAN
 The materials may vary depending upon availability.

Design Data

Design temperature/ up to 120 °C / 10 bar
 Design pressure: up to 200 °C / 8 bar

Accessories

glass protection **): plexi glass cover
 Ø42 mm,
 visual help: coloured float
 Scale: division and unity to customers spec.

*) length glass tube = CCD - 65 mm

**) length = CCD - 55, product temperature max. 80 °C

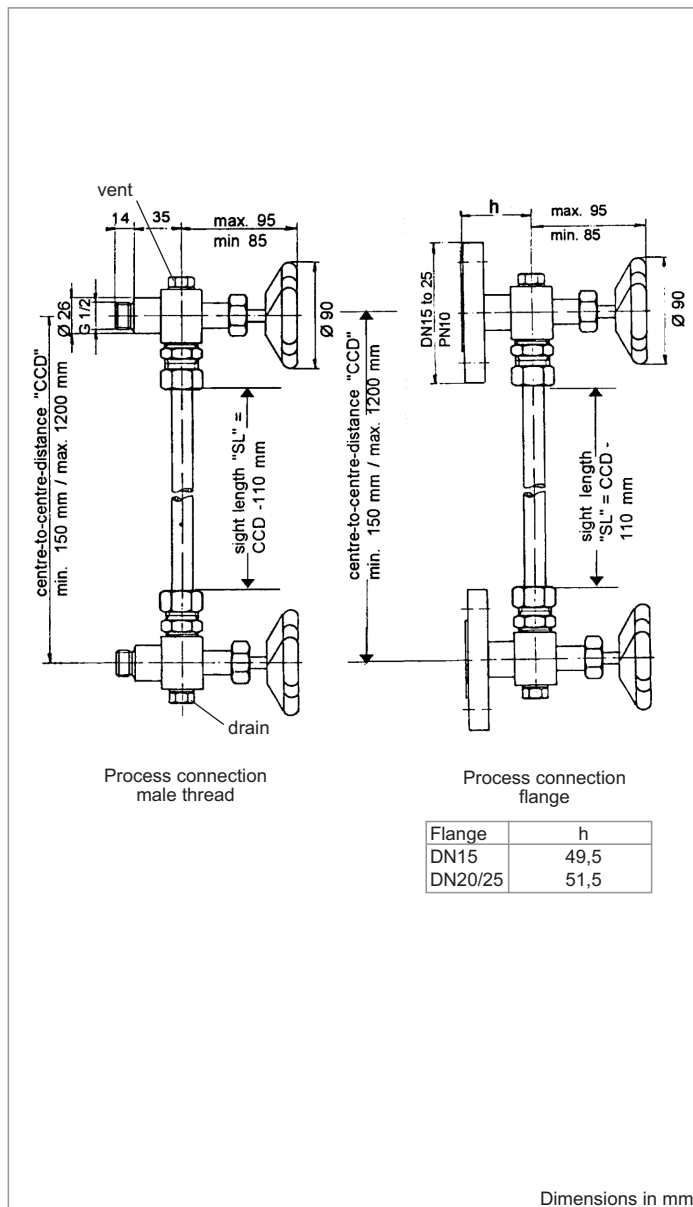

Flange	h
DN15	49,5
DN20/25	51,5

subject to alterations

Ordering no.

ME / mm

7	0	0	.	A	1	-	X	X	X	X
---	---	---	---	---	---	---	---	---	---	---



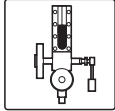

Glass Tube Liquid Level Gauge PN 10 Connection top-bottom pivoted Handwheel Glass protection	Product group 700	
	Type A2	
	Sheet: 1	Revision: 0
	Date: 08/2011	

equivalent to Vaihinger 16/14 PN10

Field of Application

Direct reading liquid level indicator with glass tube for general applications up to CL150. Increased safety with ball check valves and glass protection.

General Data

Center-to-center CCD: max. 1200 mm
 Sight length: ME - 70 mm
 Diameter of glass tube *): $\varnothing 13,5 \times 1,75$ mm
 Actuation: handwheel
 Valve passage: 8 mm
 Process connection: male thread G1/2
 DIN ISO 228
 flange DN15-25/PN10

Materials

- gauge heads: brass 2.0401
 - gaskets for glass tube: rubber (Perbunan)
 - glass tube: DURAN
 The materials may vary depending upon availability.

Design Data

Design temperature/
 Design pressure: up to 120 °C / 10 bar

Accessories

glass protection **): plexi glass cover
 $\varnothing 42$ mm
 visual help: coloured float
 Scale: division and unity to customers spec.

*) length glass tube = CCD - 20 mm
 **) length = CCD - 30, product temperature max. 80 °C
 length of brass-protection rods CCD +30 mm

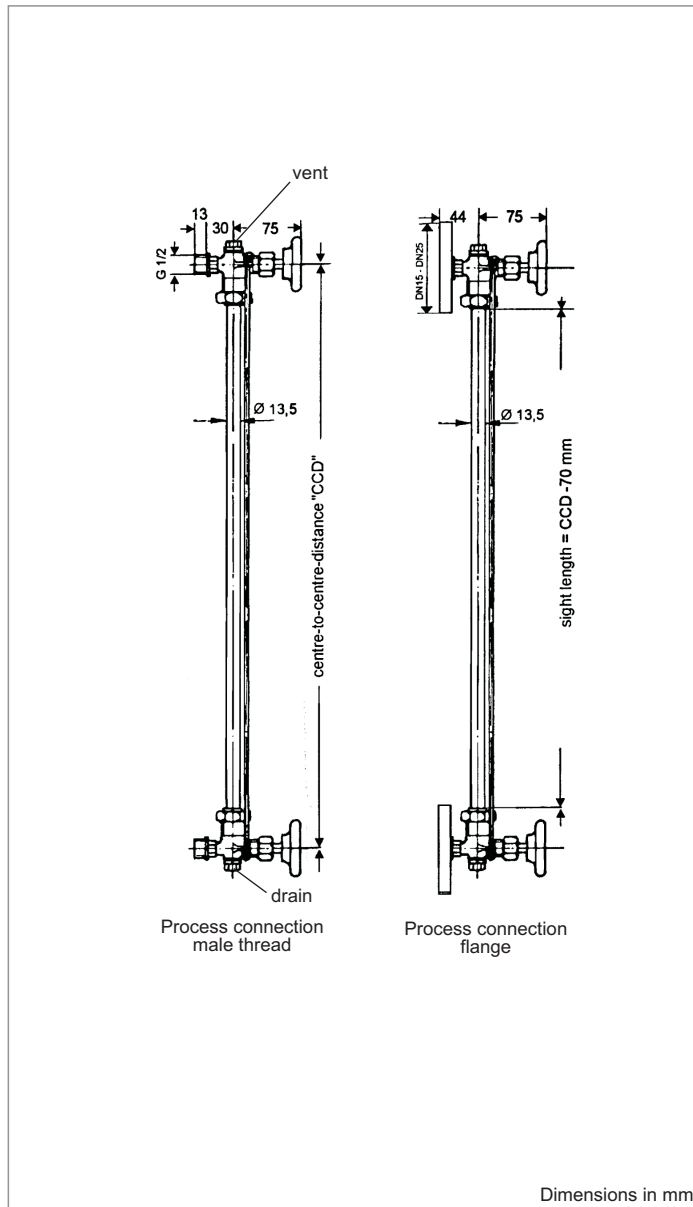

Dimensions in mm

subject to alterations

Ordering no.

ME / mm

7 | 0 | 0 | . | A | 2 | - | X | X | X | X



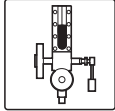

Glass Tube Liquid Level Gauge PN 10

Connection top-bottom pivoted
 Handwheel
 Glass protection

equivalent to Vaihinger 16/14 PN10

Product group **700**

Type **A3**

Sheet: 1

Revision: 0

Date:

08/2011

Field of Application

Direct reading liquid level indicator with glass tube for general applications up to CL150. Increased safety with ball check valves and glass protection.

General Data

Center-to-center CCD: max. 1200 mm
 Sight length: ME - 110 mm
 Diameter of glass tube *): $\varnothing 13,5 \times 1,75$ mm
 Actuation: handwheel
 Valve passage: 8 mm
 Process connection: male thread G1/2
 DIN ISO 228
 flange DN15-25/PN10

Materials

- gauge heads: SS 1.4571
 - gaskets for glass tube: PTFE
 - glass tube: DURAN
 The materials may vary depending upon availability.

Design Data

Design temperature/ up to 120 °C / 10 bar
 Design pressure: up to 200 °C / 8 bar

Accessories

glass protection **): plexi glass cover
 $\varnothing 42$ mm,
 coloured float
 visual help: division and unity to customers spec.

*)

length glass tube = CCD - 65 mm

**) length = CCD - 55, product temperature max. 80 °C

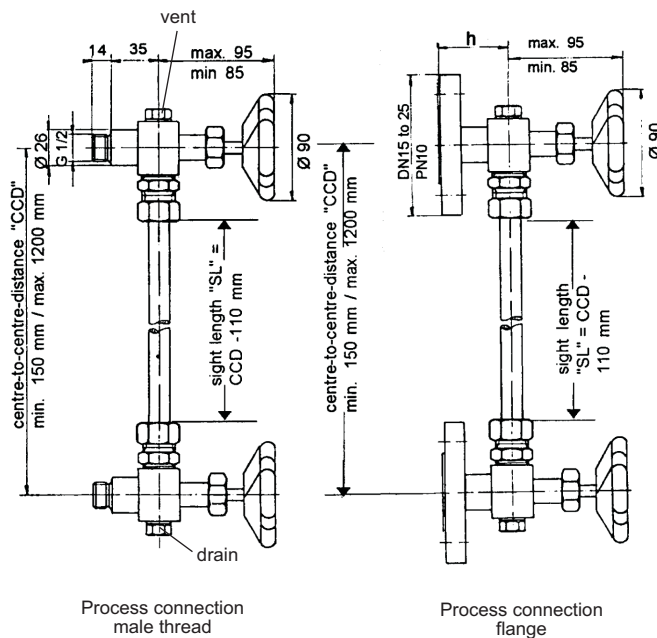

Flange	h
DN15	49,5
DN20/25	51,5

Dimensions in mm

subject to alterations

Ordering no.

ME / mm
 7 0 0 . A 3 - X X X X



ING. ROLF HEUN
 Mess- Prüf- Regeltechnik GmbH

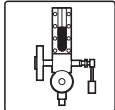

Glass Tube Liquid Level Gauge PN 10		Product group	700
Connection top-bottom pivoted Without gauge heads Glass protection		Type	A4
		Sheet: 1	Revision: 0
		Date:	08/2011

equivalent to Vaihinger 16/16 PN10

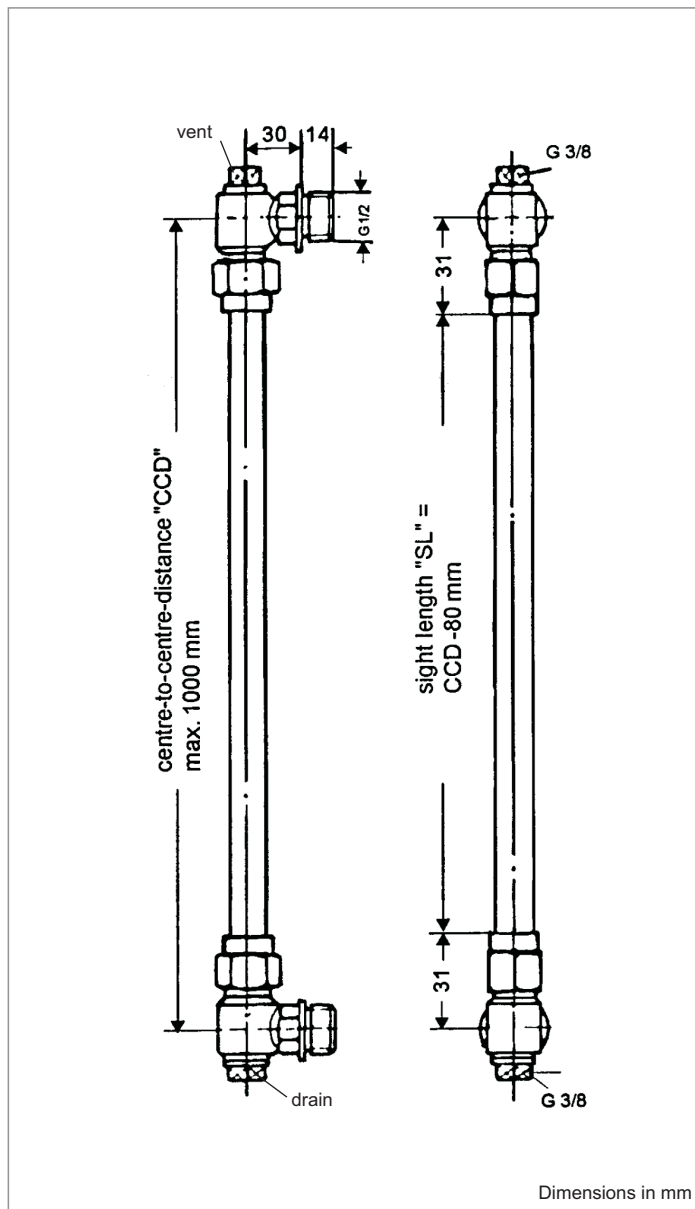

Field of Application

Direct reading liquid level indicator with glass tube for general applications up to CL150. Increased safety with optional glass protection.

General Data

Center-to-center CCD: max. 1000 mm
 Sight length: ME - 80 mm
 Diameter of glass tube *): Ø13,5 x 1,75 mm)
 Process connection: male thread G1/2
 DIN ISO 228
 flange DN15-25/PN10

Materials

- gauge heads: SS 1.4571
 - gaskets for glass tube: PTFE
 - glass tube: DURAN
 The materials may vary depending upon availability.

Design Data

Design temperature/ up to 100 °C / 10 bar
 Design pressure: up to 200 °C / 8 bar

Accessories

glass protection **: plexi glass cover
 Ø42 mm
 visual help: coloured float
 Scale: division and unity to customers spec.

*)

length glass tube = CCD - 20 mm

**) length = CCD - 30, product temperature max. 80 °C

subject to alterations

Ordering no.

ME / mm
 7 | 0 | 0 | . | A | 4 | - | X | X | X | X



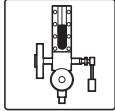

Sight Glass Level Gauge Glass tube D16

Connection top-bottom pivoted
 Offset, handwheel
 Glass protection

Product group **700**

Type **01**

Sheet: 1 Revision: 1

Date: 11/2011

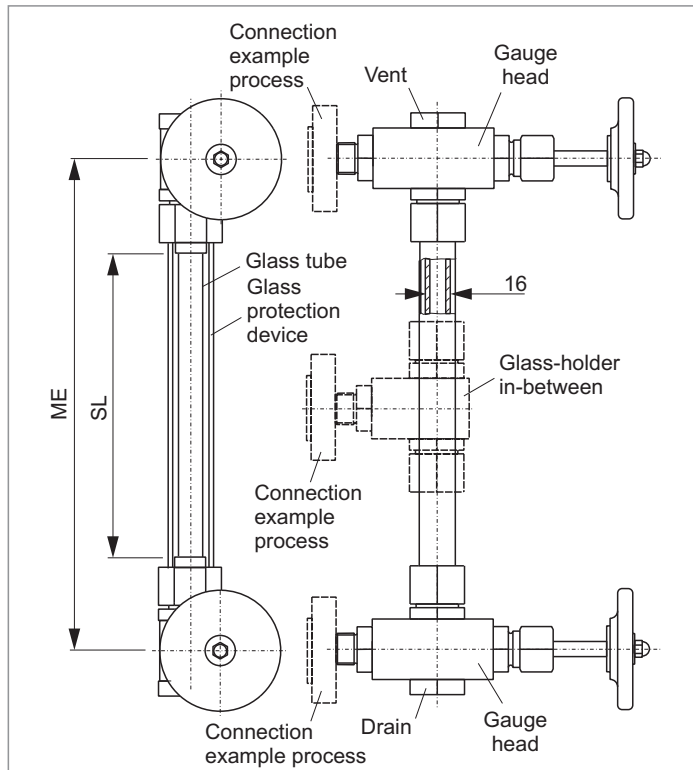

Field of Application

Direct reading liquid level indicator with glass tube for general applications up to CL150. Increased safety with ball check valves and glass protection.

General Data

Visible length SL: ME-130 mm
 from 1500 mm and up every 1000 mm glass-holder in-between union, flange
 Process connection: s. datasheet 760.01
 Gauge valve types: hand wheel
 Actuation: Borosilicate
 Material glass tube: CS, SS
 Material media wetted parts: Acrylic glass/SS
 Material glass protection device: Viton
 Material sealing glass tube: Viton
 Types with special materials e. g. Hastelloy, Monel etc. are available.
 Weight
 - basic weight for ME ≤1500 mm: 3,6 kg
 - basic weight for ME >1500 mm: 4,9 kg
 - + weight/m: 0,2 kg
 - weight glass protection device/m: 0,2 kg

Design Data

Design pressure-temperature: -20...+200 °C/
 0 ... 25 bar

Further Data

Process connection: see 700.VAR
 Vent: see 700.VAR
 Drain: see 700.VAR

Accessories

Scale: see accessories 700

Spare parts

Glass tube: length = ME -40
 Gasket: 0160022015VI

CS (= carbon steel) and SS (= stainless steel type 316SS) are materials suitable for Pressure Vessels according to EN or ASME.

Subject to alterations

Orientation of gauge valve and operation

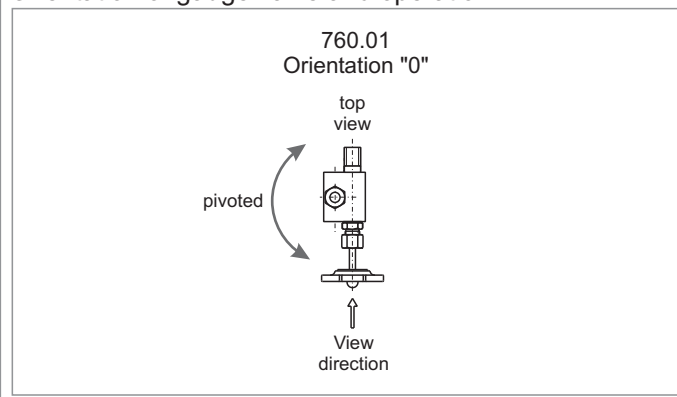

Ordering no.

7 0 0 0 1 0 0 0 1 0 Q 0 - 0 0 -										see 700.VAR										ME [mm]			
										X X X X X X X X X X										X X X X			
Glass-holder in-between	without (ME ≤1500)	0																					
	with (ME >1500 mm)	1																					
Gauge valve	760.01	0	1	0	see Datasheet 760.01												orientation gauge valve						



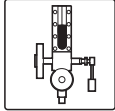

Sight Glass Level Gauge Glass tube D16

Connection top-bottom pivoted
 Offset, quick closing
 Glass protection

Product group **700**

Type **03**

Sheet: 1 Revision: 0

Date: 08/2011

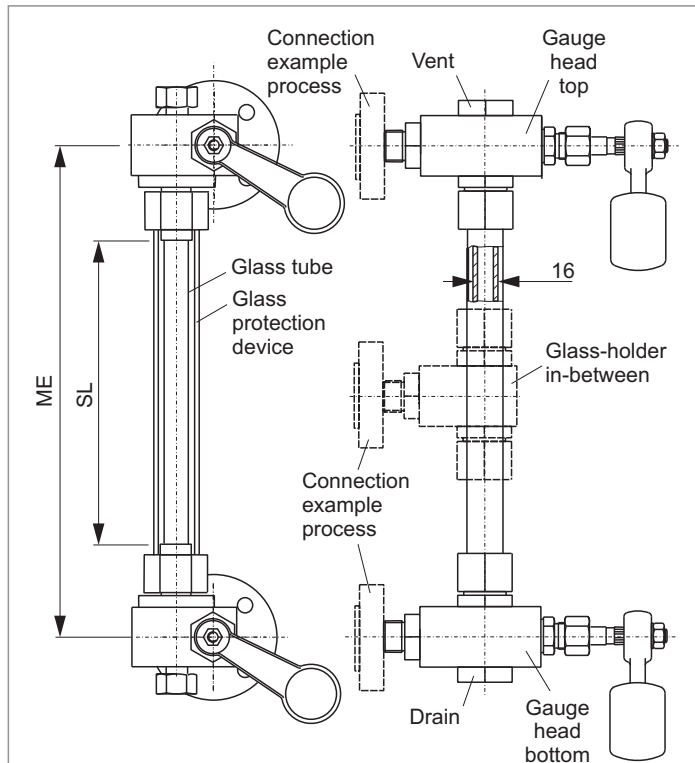

Field of Application

Direct reading liquid level indicator with glass tube for general applications up to CL150. Increased safety with ball check valves and glass protection.

General Data

Visible length SL: ME-130 mm
 from 1500 mm and up every 1000 mm glass-holder in-between union, flange
 Gauge valve types: s. datasheet 760.03
 Actuation: quick closing
 Material glass tube: Borosilicate
 Material media wetted parts: CS, SS
 Material glass protection device: Acrylic glass/SS
 Material sealing glass tube: Viton
 Types with special materials e. g. Hastelloy, Monel etc. are available.
 Weight
 - basic weight for ME ≤1500 mm: 3,6 kg
 - basic weight for ME >1500 mm: 4,9 kg
 - + weight/m: 0,2 kg
 - weight glass protection device/m: 0,2 kg

Design Data

Design pressure/-temperature: -20...+200 °C/
 0...25 bar

Further Data

Process connection: see 700.VAR
 Vent: see 700.VAR
 Drain: see 700.VAR

Accessories

Scale: see accessories 700

Spare parts

Glass tube: length = ME -40
 Gasket: 0160022015V1

CS (= carbon steel) and SS (= stainless steel type 316SS) are materials suitable for Pressure Vessels according to EN or ASME.

Subject to alterations

Orientation of gauge valve and operation

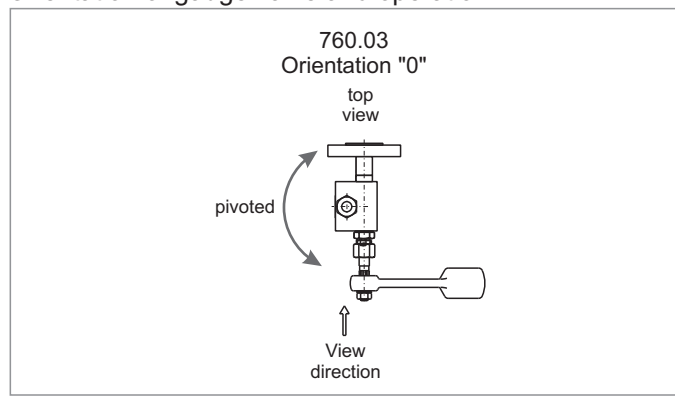

Ordering no.

7 0 0 0 3 0 0 0 3 0 Q 0 - 0 0 - X X X X X X X X X X - X X X X X											
see 700.VAR											
ME [mm]											
Glass-holder in-between	without (ME ≤1500)	0								with (ME >1500 mm)	1
Gauge valve	760.03	0 3 0	see Datasheet 760.03				orientation gauge valve				



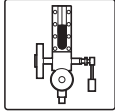

Gauge valve CL 1500

Handwheel
 Nipple connection to gauge
 Straight seat
 Spindle screw inside, seat renewable
 Special execution up to 2500 lbs

Product group **760**

Type **51**

Sheet: 1 Revision: 0

Date: 08/2011

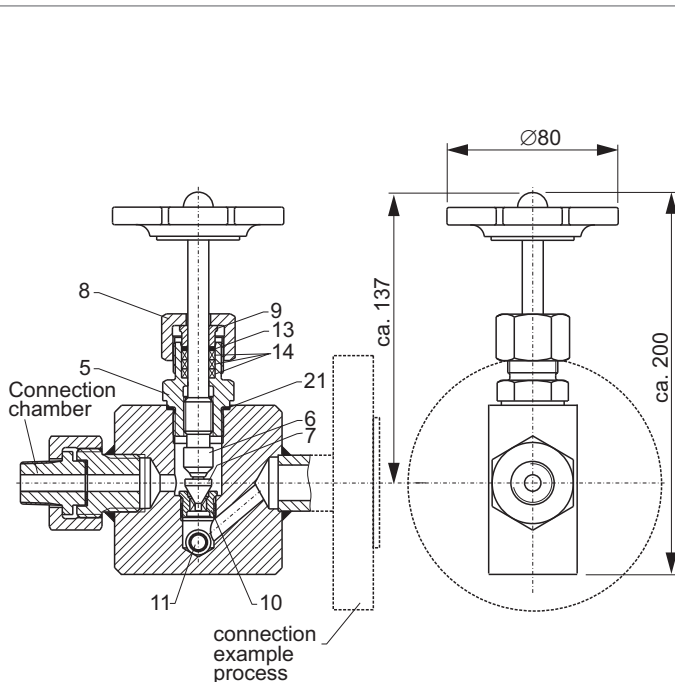

Field of Application

The gauge valve is to close the tank against the level gauge. It is actuated by a handwheel. As a standard an automatic ball check is integrated. The process connection is manufactured acc. to customer's specification.

General Data

Material
 - Housing, nipple, flange: CS or SS
 - Trim: SS
 other materials on request
 Orientation: horizontally, see Fig. orientation
 Ball check diff. pressure: >0,5 bar
 Process connection: DIN/ANSI acc. to cust. spec.
 Weight: ca. 2,5 kg

Design Data

Operating pressure: up to 25 MPa/1500 lbs
 Temperature media:
 Housing, nipple, flange SS: -200 ... +400 °C
 Housing, nipple, flange CS: -10 ... +400 °C

Orientation

Examples

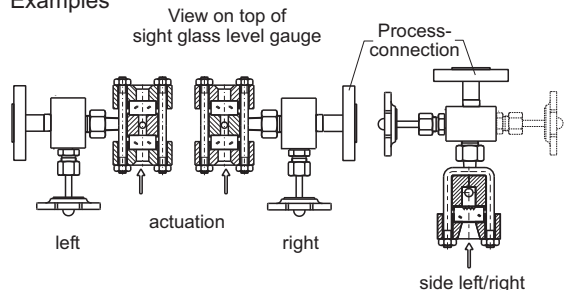

Measures in mm

Spare parts kit **BG5XHEKIT** consisting of:

Pos.	Denomination	Dimension	Material
5	Bonnet	5720124159B	SS
6	Spindle	5650320759	SS
7	Cone	5610255459	SS
8	Nut	5921024059B	SS
9	Stuffing box	5706010059	SS
13	Base ring	0100016020SI	SIL4400
14	Packing	0016001040GR	Graphit
10	Seat	5604120459	SS
11	Ball	D054011120	SS
21	Sealing	D07603121026	SS

CS (= carbon steel) rsp. SS (= stainless steel type 316SS) are materials suitable for pressure vessels according to EN oder ASME.

subject to alterations

Ordering no.

7 6 0 . 5 1 X X - X - - - X X X

X	X	X	see 700.VAR	Connection process
S	CS			Material
4	SS			
0	F	Stuffing box		spindle sealing
		Bellows		



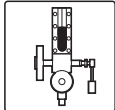

Gauge valve CL 1500

Handwheel
 Nipple connection to gauge
 Angle seat
 Spindle screw inside, seat renewable
 Special execution up to 2500 lbs

Product group **760**

Type **52**

Sheet: 1 Revision: 0

Date: 08/2011

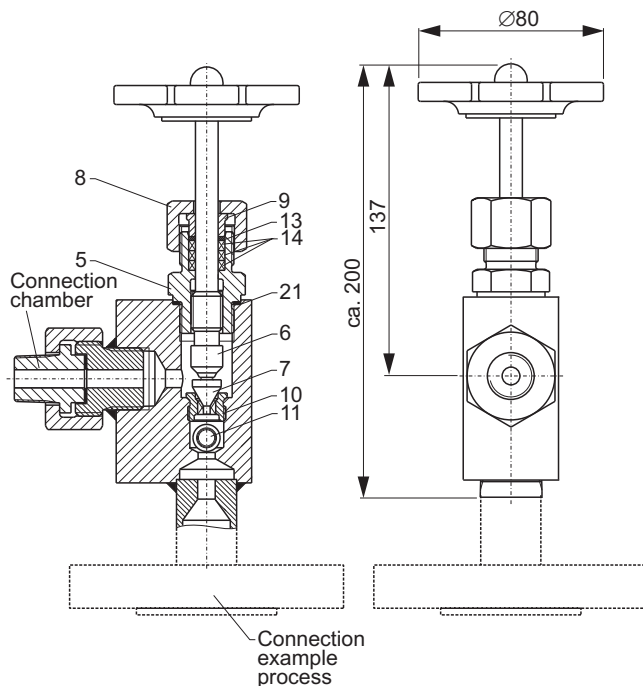

Measures in mm

Spare parts kit **BG5XHEKIT** consisting of:

Pos.	Denomination	Dimension	Material
5	Bonnet	5720124159B	SS
6	Spindle	5650320759	SS
7	Cone	5610255459	SS
8	Nut	5921024059B	SS
9	Stuffing box	5706010059	SS
13	Base ring	0100016020SI	SIL4400
14	Packing	0016001040GR	Graphit
10	Seat	5604120459	SS
11	Ball	D054011120	SS
21	Sealing	D07603121026	SS

Field of Application

The gauge valve is to close the tank against the level gauge. It is actuated by a handwheel. As a standard an automatic ball check is integrated. The process connection is manufactured acc. to customer's specification.

General Data

Material
 - Housing, nipple, flange: CS or SS
 - Trim: SS
 other materials on request
 Orientation: horizontally, see Fig. orientation
 Ball check diff. pressure: >0,5 bar
 Process connection: DIN/ANSI acc. to cust. spec.
 Weight: ca. 2,0 kg

Design Data

Operating pressure: up to 25 MPa/1500 lbs
 Temperature media:
 Housing, nipple, flange SS: -200 ... +400 °C
 Housing, nipple, flange CS: -10 ... +400 °C

Orientation

Examples

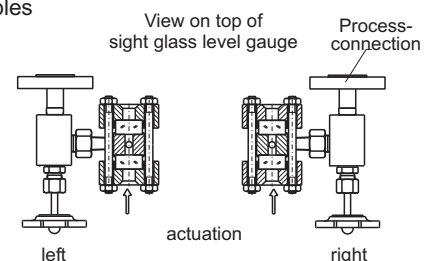

CS (= carbon steel) rsp. SS (= stainless steel type 316SS) are materials suitable for pressure vessels according to EN oder ASME.

subject to alterations

Ordering no.

7 6 0 . 5 2 X X - X _ _ _ X X X

X	X	X	see 700.VAR	Connection process
S	CS			Material
4	SS			
0	F	Stuffing box		spindle sealing
		Bellows		



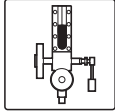

Gauge valve CL 1500

Handwheel
 Nipple connection to gauge
 Angle seat, offset
 Spindle screw inside, seat renewable
 Special execution up to 2500 lbs

Product group **760**

Type **53**

Sheet: 1

Revision: 0

Date:

08/2011

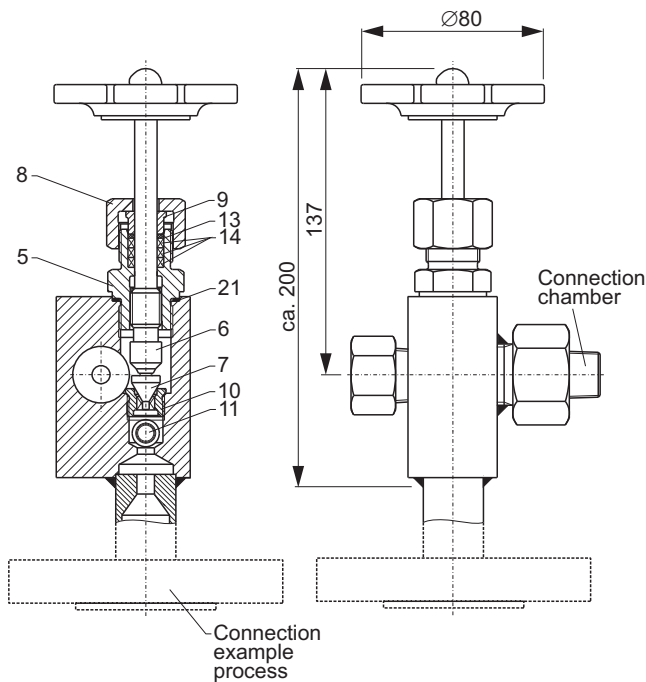

Measures in mm

Spare parts kit **BG5XHEKIT** consisting of:

Pos.	Denomination	Dimension	Material
5	Bonnet	5720124159B	SS
6	Spindle	5650320759	SS
7	Cone	5610255459	SS
8	Nut	5921024059B	SS
9	Stuffing box	5706010059	SS
13	Base ring	0100016020SI	SIL4400
14	Packing	0016001040GR	Graphit
10	Seat	5604120459	SS
11	Ball	D054011120	SS
21	Sealing	D07603121026	SS

Field of Application

The gauge valve is to close the tank against the level gauge. It is actuated by a handwheel. As a standard an automatic ball check is integrated. The process connection is manufactured acc. to customer's specification.

General Data

Material
 - Housing, nipple, flange: CS or SS
 - Trim: SS
 other materials on request
 Orientation: horizontally, see Fig. orientation
 Ball check diff. pressure: >0,5 bar
 Process connection: DIN/ANSI acc. to cust. spec.
 Weight: ca. 2,0 kg

Design Data

Operating pressure: up to 25 MPa/1500 lbs
 Temperature media:
 Housing, nipple, flange SS: -200 ... +400 °C
 Housing, nipple, flange CS: -10 ... +400 °C

Orientation

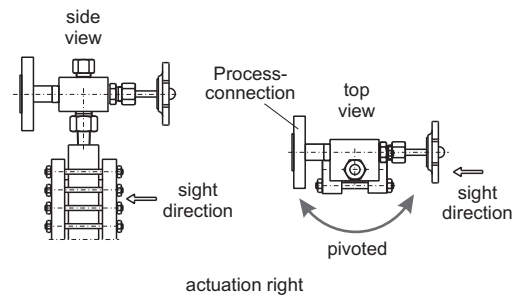

CS (= carbon steel) resp. SS (= stainless steel type 316SS) are materials suitable for pressure vessels according to EN oder ASME.

subject to alterations

Ordering no.

7 6 0 . 5 3 X X - X - - - X X X

X	X	X	see 700.VAR	Connection process
S	CS			Material
4	SS			
-		Stuffing box		spindle sealing
0	F	Bellows		



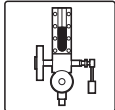

Gauge valve CL 600

Quick closing lever
 Nipple connection to gauge
 Straight seat
 Spindle screw inside
 Seat renewable

Product group **760**

Type **56**

Sheet: 1 Revision: 0

Date: 08/2011

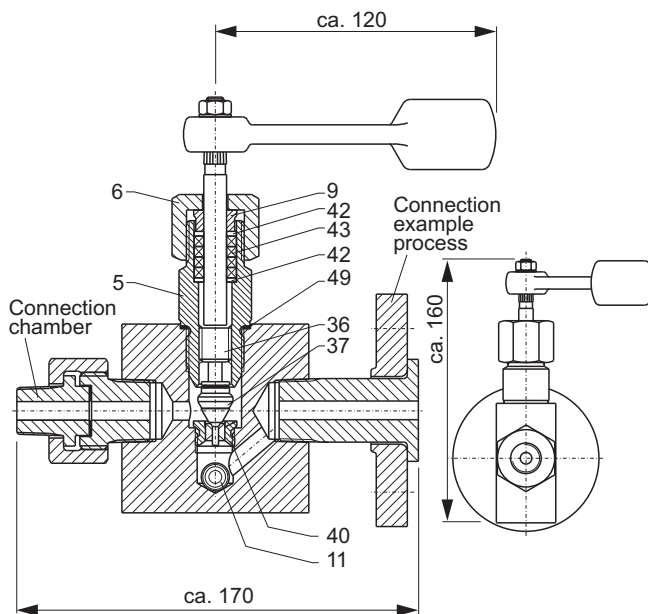

Measures in mm

Spare parts kit **BG5XSEKIT** consisting of:

Pos.	Denomination	Dimension	Material
5	Bonnet	5720124259B	SS
36	Spindle	5650320859	SS
37	Cone	5610255459	SS
6	Nut	5921024059B	SS
9	Stuffing box	5706010059	SS
42	Base ring	0100016020SI	SIL4400
43	Packing	0016001040GR	Graphit
40	Seat	5604120459	SS
11	Ball	D054011120	SS
49	Sealing	D07603121026	SS

Field of Application

The gauge valve is to close the tank against the level gauge. It is actuated by a lever. As a standard an automatic ball check is integrated. The process connection is manufactured acc. to customer's specification.

General Data

Material
 - Housing, nipple, flange: CS or SS
 - Trim: SS
 other materials on request
 Orientation: horizontally, see Fig. orientation
 Ball check diff. pressure: >0,5 bar
 Process connection: DIN/ANSI acc. to cust. spec.
 Weight: ca. 1,5 kg

Design Data

Operating pressure: up to 10 MPa/600 lbs
 Temperature media:
 Housing, nipple, flange SS: -200 ... +400 °C
 Housing, nipple, flange CS: -10 ... +400 °C

Orientation

Examples

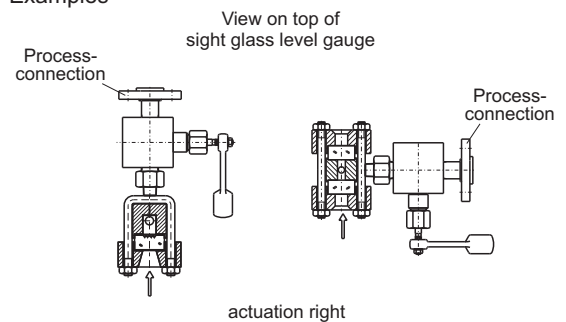

CS (= carbon steel) resp. SS (= stainless steel type 316SS) are materials suitable for pressure vessels according to EN oder ASME.

subject to alterations

Ordering no.

7 6 0 . 5 6 - X _ _ _ _ X X X

S	CS	see 700.VAR	Connection process
4	SS		



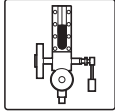

Gauge valve CL 600

Quick closing lever
 Nipple connection to gauge
 Angle seat
 Spindle screw inside
 Seat renewable

Product group **760**

Type **57**

Sheet: 1

Revision: 0

Date:

08/2011

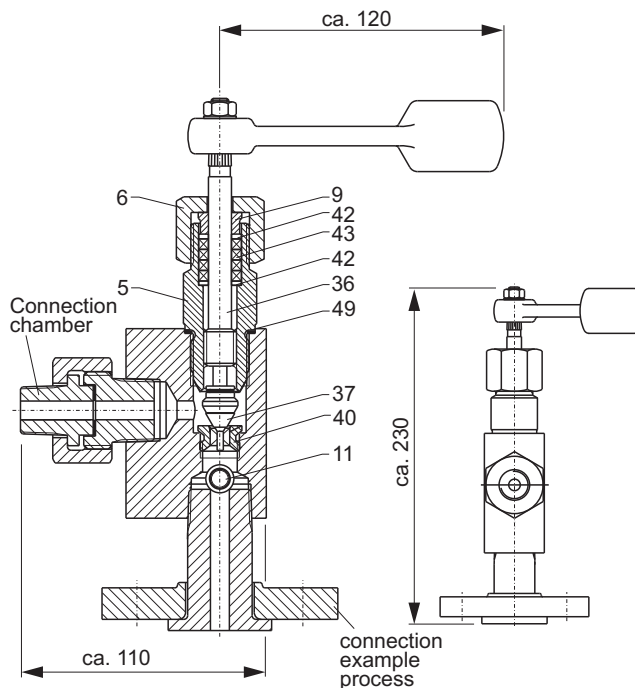

Measures in mm

Spare parts kit **BG5XSEKIT** consisting of:

Pos.	Denomination	Dimension	Material
5	Bonnet	5720124259B	SS
36	Spindle	5650320859	SS
37	Cone	5610255459	SS
6	Nut	5921024059B	SS
9	Stuffing box	5706010059	SS
42	Base ring	0100016020SI	SIL4400
43	Packing	0016001040GR	Graphit
40	Seat	5604120459	SS
11	Ball	D054011120	SS
49	Sealing	D07603121026	SS

Field of Application

The gauge valve is to close the tank against the level gauge. It is actuated by a lever. As a standard an automatic ball check is integrated. The process connection is manufactured acc. to customer's specification.

General Data

Material
 - Housing, nipple, flange: CS or SS
 - Trim: SS
 other materials on request
 Orientation: horizontally, see Fig. orientation
 Ball check diff. pressure: >0,5 bar
 Process connection: DIN/ANSI acc. to cust. spec.
 Weight: ca. 1,5 kg

Design Data

Operating pressure: up to 10 MPa/600 lbs
 Temperature media:
 Housing, nipple, flange SS: -200 ... +400 °C
 Housing, nipple, flange CS: -10 ... +400 °C

Orientation

Examples

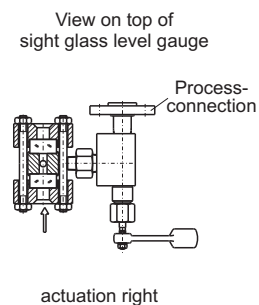

CS (= carbon steel) resp. SS (= stainless steel type 316SS) are materials suitable for pressure vessels according to EN oder ASME.

subject to alterations

Ordering no.

7 6 0 . 5 7 - X _ _ _ _ X X X

		X	X	X	see 700.VAR	Connection process
S	CS					Material
4	SS					



ING. ROLF HEUN
 Mess- Prüf- Regeltechnik GmbH

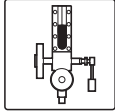

Gauge valve CL 600

Quick closing lever
 Nipple connection to gauge
 Angle seat, offset
 Spindle screw inside
 Seat renewable

Product group **760**

Type **58**

Sheet: 1

Revision: 0

Date:

08/2011

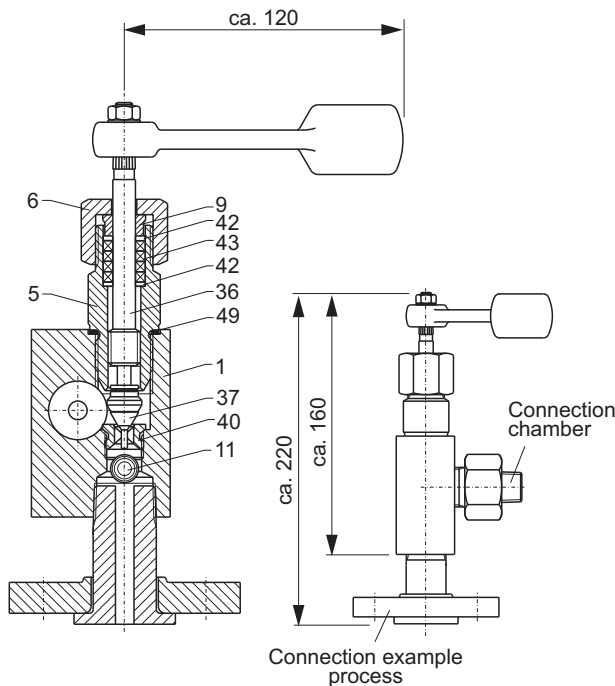

Measures in mm

Spare parts kit **BG5XSEKIT** consisting of:

Pos.	Denomination	Dimension	Material
5	Bonnet	5720124259B	SS
36	Spindle	5650320859	SS
37	Cone	5610255459	SS
6	Nut	5921024059B	SS
9	Stuffing box	5706010059	SS
42	Base ring	0100016020SI	SIL4400
43	Packing	0016001040GR	Graphit
40	Seat	5604120459	SS
11	Ball	D054011120	SS
49	Sealing	D07603121026	SS

Field of Application

The gauge valve is to close the tank against the level gauge. It is actuated by a lever. As a standard an automatic ball check is integrated. The process connection is manufactured acc. to customer's specification.

General Data

Material
 - Housing, nipple, flange: CS or SS
 - Trim: SS
 other materials on request
 Orientation: horizontally, see Fig. orientation
 Ball check diff. pressure: >0,5 bar
 Process connection: DIN/ANSI acc. to cust. spec.
 Weight: ca. 1,5 kg

Design Data

Operating pressure: up to 10 MPa/600 lbs
 Temperature media:
 Housing, nipple, flange SS: -200 ... +400 °C
 Housing, nipple, flange CS: -10 ... +400 °C

Orientation

Examples

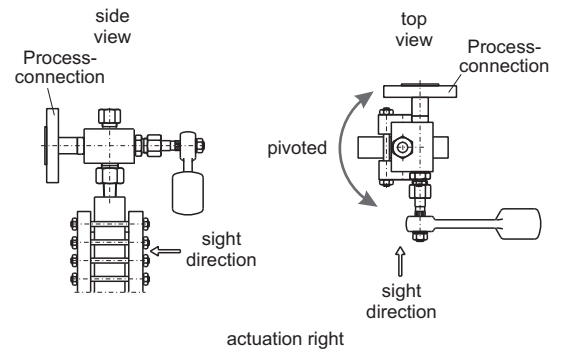

CS (= carbon steel) resp. SS (= stainless steel type 316SS) are materials suitable for pressure vessels according to EN oder ASME.

subject to alterations

Ordering no.

7 6 0 . 5 8 - X _ _ _ _ X X X

S	CS	see 700.VAR	Connection process
4	SS		



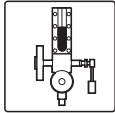

Gauge valve CL 1500

Handwheel
 Angle seat, offset
 Spindle screw inside
 Seat renewable

Product group **760**

Type **01**

Sheet: 1 Revision: 0

Date: 08/2011

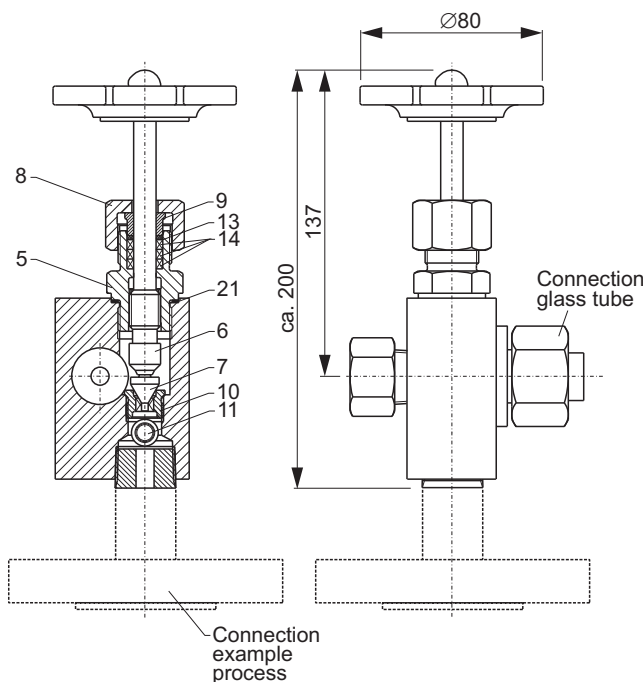

Measures in mm

Spare parts kit **BG5XHEKIT** consisting of:

Pos.	Denomination	Dimension	Material
5	Bonnet	5720124159B	SS
6	Spindle	5650320759	SS
7	Cone	5610255459	SS
8	Nut	5921024059B	SS
9	Stuffing box	5706010059	SS
13	Base ring	0100016020SI	SIL4400
14	Packing	0016001040GR	Graphit
10	Seat	5604120459	SS
11	Ball	D054011120	SS
21	Sealing	D07603121026	SS

Field of Application

The gauge valve is to close the tank against the level gauge. It is actuated by a handwheel. As a standard an automatic ball check is integrated. The process connection is manufactured acc. to customer's specification.

General Data

Material
 - Housing, nipple, flange: CS or SS
 - Trim: SS
 other materials on request
 Orientation: horizontally, see Fig. orientation
 Ball check diff. pressure: >0,5 bar
 Process connection: DIN/ANSI acc. to cust. spec.
 Weight: ca. 2,0 kg

Design Data

Operating pressure: up to 25 MPa/1500 lbs
 Temperature media:
 Housing, nipple, flange SS: -200 ... +400 °C
 Housing, nipple, flange CS: -10 ... +400 °C

Orientation

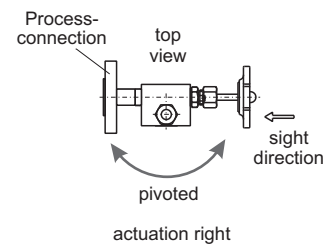

CS (= carbon steel) resp. SS (= stainless steel type 316SS) are materials suitable for pressure vessels according to EN oder ASME.

subject to alterations

Ordering no.

7 6 0 . 0 1 X X - X - - - X X X

X	X	X	see 700.VAR	Connection process
S	CS			Material
4	SS			
-		Stuffing box		spindle sealing
0	F	Bellows		



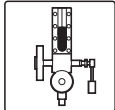

Gauge valve CL 600

Quick closing lever
 Angle seat, offset
 Spindle screw inside
 Seat renewable

Product group **760**

Type **03**

Sheet: 1 Revision: 0

Date: 08/2011

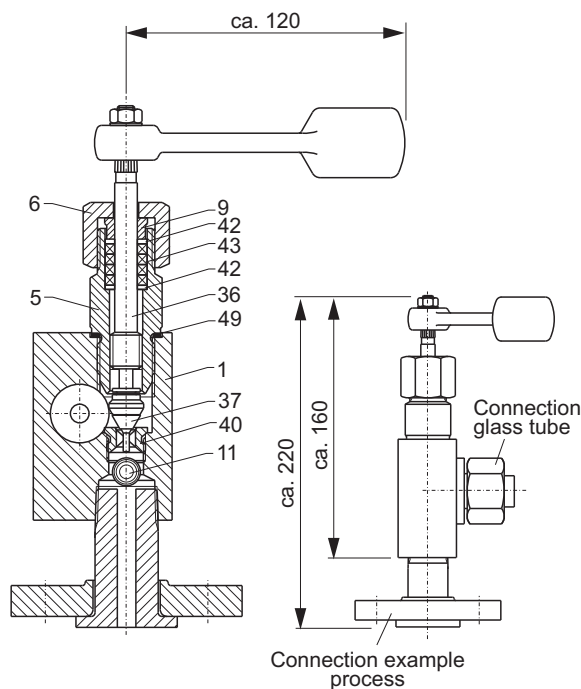

Measures in mm

Spare parts kit **BG5XSEKIT** consisting of:

Pos.	Denomination	Dimension	Material
5	Bonnet	5720124259B	SS
36	Spindle	5650320859	SS
37	Cone	5610255459	SS
6	Nut	5921024059B	SS
9	Stuffing box	5706010059	SS
42	Base ring	0100016020SI	SIL4400
43	Packing	0016001040GR	Graphit
40	Seat	5604120459	SS
11	Ball	D054011120	SS
49	Sealing	D07603121026	SS

Field of Application

The gauge valve is to close the tank against the level gauge. It is actuated by a quick closing lever. As a standard an automatic ball check is integrated. The process connection is manufactured acc. to customer's specification.

General Data

Material
 - Housing, nipple, flange: CS or SS
 - Trim: SS
 other materials on request
 Orientation: horizontally, see Fig. orientation
 Ball check diff. pressure: >0,5 bar
 Process connection: DIN/ANSI acc. to cust. spec.
 Weight: ca. 1,5 kg

Design Data

Operating pressure: up to 10 MPa/600 lbs
 Temperature media:
 Housing, nipple, flange SS: -200 ... +400 °C
 Housing, nipple, flange CS: -10 ... +400 °C

Orientation

Examples

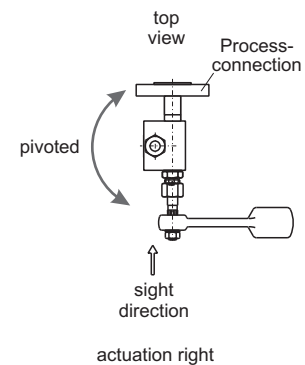

CS (= carbon steel) resp. SS (= stainless steel type 316SS) are materials suitable for pressure vessels according to EN oder ASME.

subject to alterations

Ordering no.

7 6 0 . 0 3 - X _ _ _ _ X X X

X	X	X	see 700.VAR	Connection process
S	CS			Material
4	SS			



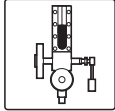

Gauge valve, CL 300

Lever and quick closing
 Angle seat
 Spindle thread inside
 Seats and cone are renewable
 flanged

Equivalent to Vaihinger 17/1

Product group **760**

Type **11**

Sheet: 1

Revision: 0

Date:

08/2011

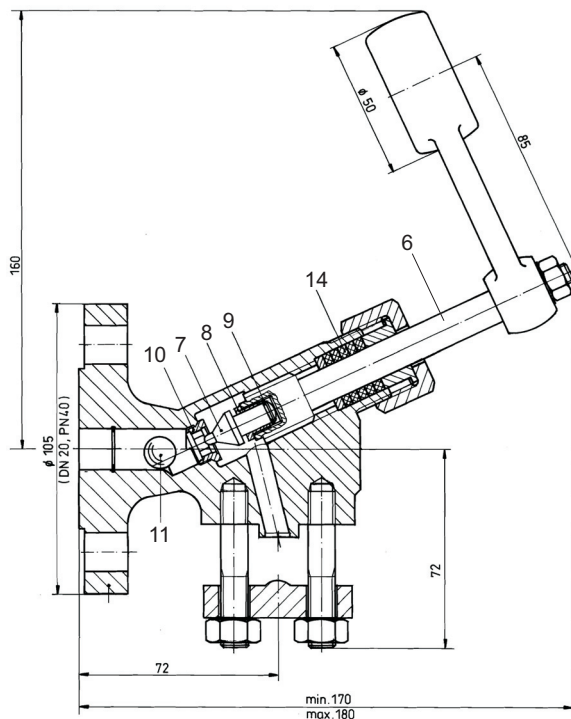

Dimensions in mm

Pos.	Pcs.	Denomination	Order no.	Material
6	1	Spindle	3094553	1.4104
7	1	Cone	3095354	1.4305
8	1	Screw connect.	"	1.4305
9	1	Semi-lunar ring	"	1.1750
10	1	Seat	2602C54	1.4305
11	1	Sphere	D054011011	1.4401
14	4	Packing	0021001360GR	Reingraphit

Field of Application

The gauge valve is to close the vessel against the level gauge. It is actuated by a quick closing lever. As a standard an automatic ball check is integrated. The process connection is manufactured acc. to customer's specification.

General Data

Orientation: horizontally,
 valve opening: 8 mm
 Material
 - Housing, flange: CS
 - Trim: SS
 other materials on request
 Ball check diff. pressure: >1 bar
 Process connection: DIN/EN/ANSI acc. to cust. spec.
 Weight: ca. 5,0 kg

Design Data

Nominal pressure: CL 300
 Design temp./Design pressure: -10 ... +243 °C/30 bar

CS (= carbon steel) rsp. SS (= stainless steel type 316SS) are materials suitable for pressure vessels according to EN or ASME.

subject to alterations

Ordering no.

7 6 0 . 1 1 - _ _ _ _ X X X

X X X See 700.VAR Process connection



ING. ROLF HEUN
 Mess- Prüf- Regeltechnik GmbH

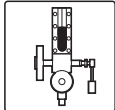

Gauge valve, CL 900

Double shut-off with hand wheel and quick closing
 Angle seat
 Spindle thread inside
 Seats and cone are renewable
 flanged

Equivalent to Vaihinger 18/1

Product group **760**

Type **18**

Sheet: 1 Revision: 0

Date: 08/2011

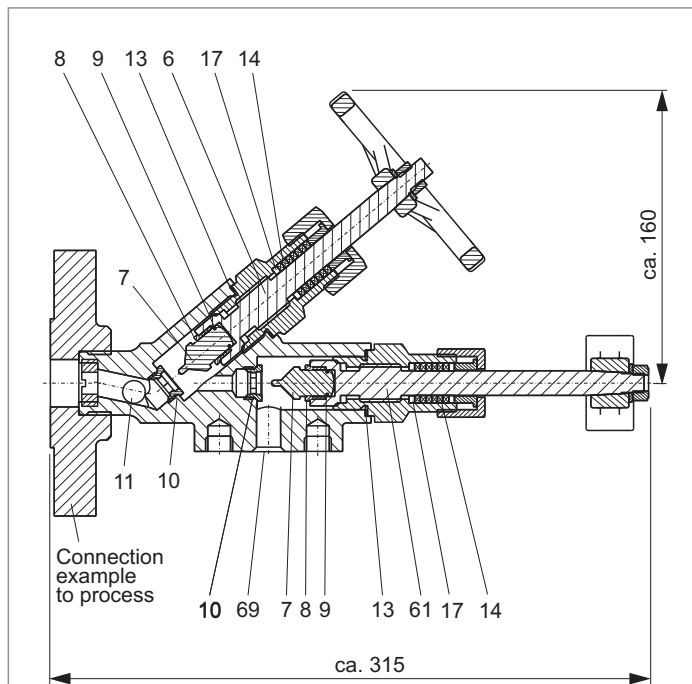

Dimensions in mm

Spare parts kit **BG181HEKIT** (hand wheel, ball) consisting of:

Pos.	Denomination	Dimension	Material
6	Spindle	3396G53	SS
7	Cone	2811254	SS
8	Screw connect.	277154	SS
9	Semi-lunar ring	18202	SS
13	Sealing	D07603S35028	1.1003
14	Packing	0021001360GR	Graphite
17	Bottom ring	2586135	1.0501
10	Seat	2790b54	SS
11	Ball	D054011014	SS
69	Lens gasket	218238	1.0305

Spare parts kit **BG181SEKIT** (lever) consisting of:

Pos.	Denomination	Dimension	Material
61	Spindle	3397GB53	SS
7	Cone	2811254	SS
8	Screw connect.	277154	SS
9	Semi-lunar ring	18202	SS
13	Sealing	D07603S35028	1.1003
14	Packing	0021001360GR	Graphite
17	Bottom ring	2586135	1.0501
10	Seat	2790b54	SS

Field of Application

The gauge valve is to close the vessel against the level gauge. It is actuated by a hand wheel and quick closing lever. As a standard an automatic ball check is integrated. The process connection is manufactured acc. to customer's specification.

General Data

Valve pass: 8 mm
 Material
 - Housing, nipple, flange: CS
 - Trim: SS
 other materials on request
 Orientation: horizontally, see Fig. orientation
 Ball check diff. pressure: >0,5 bar
 Process connection: DIN/ANSI acc. to cust. spec.
 Weight: ca. 5,0 kg

Design Data

Nominal pressure: CL 900
 Design temp./
 design pressure max: -10 ... +350 °C/120 bar

CS (= carbon steel) resp. SS (= stainless steel type 316SS) are materials suitable for pressure vessels according to EN or ASME.

subject to alterations

Ordering no.

7 6 0 . 1 8 - _ _ _ _ X X X
 X X X see 700.VAR Process connection



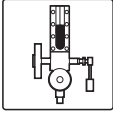

Gauge valve, CL1500

Double shut-off with hand wheel and quick closing
Angle seat
Spindle thread inside
Seats and cone are renewable
flanged

Equivalent to Vaihinger 18/2

Product group **760**

Type **19**

Sheet: 1

Revision: 0

Date:

08/2011

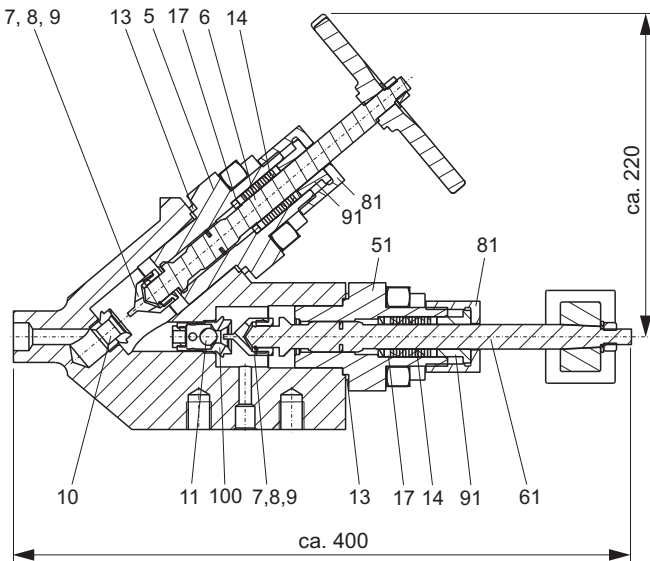

Dimensions in mm

Spare parts kit **BG182HEKIT** (hand wheel) consisting of:

Pos.	Denomination	Ordering-No.	Material
5	Bonnet	3269149B	1.5415
6	Spindle	1615G53	SS
7	Cone	190954	SS
8	Screw connect.	1617a53	SS
9	Semi-lunar ring	18203	SS
13	Sealing	D07603S49040	1.1003
14	Packing	0026001660GI	Graphit
17	Bottom ring	162035	1.0501
10	Seat	405F254	SS
81	Nut	WK165835B	1.0501
91	Stuffing box	1657135	1.0501

Spare parts kit **BG182SEKIT** (lever, ball) consisting of:

Pos.	Denomination	Ordering-No.	Material
51	Bonnet	32691149B	1.5415
61	Spindle	1696253	SS
7	Cone	190954	SS
8	Screw connect.	1617a53	SS
9	Semi-lunar ring	18203	SS
13	Sealing	D07603S49040	1.1003
14	Packing (8)	0026001660GI	Graphit
17	Bottom ring	162035	1.0501
100	Seat w. ball carrier	418W11054	SS
11	Ball	D054011011	SS
81	Nut	WK165835B	1.0501
91	Stuffing box	1657135	1.0501

Field of Application

The gauge valve is to close the vessel against the level gauge. It is actuated by a hand wheel and quick closing lever. As a standard an automatic ball check is integrated. The process connection is manufactured acc. to customer's specification.

General Data

Valve pass: 8 mm
Material:
- Housing, nipple, flange: CS
- Trim: SS
other materials on request
Orientation: horizontally, see Fig. orientation
Ball check diff. pressure: >0,5 bar
Process connection: DIN/ANSI acc. to cust. spec.
Weight: ca. 5,0 kg

Design Data

Nominal pressure: CL1500
Design temp./Design pressure: -10 ... +374 °C/165 bar

CS (= carbon steel) resp. SS (= stainless steel type 316SS) are materials suitable for pressure vessels according to EN or ASME.

subject to alterations

Ordering no.

7 6 0 . 1 9 - - - - - X X X

X X X see 700.VAR Process connection



ING. ROLF HEUN
Mess- Prüf- Regeltechnik GmbH

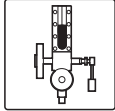

Gauge valve, CL 600

Lever, quick closing
 Angle seat
 Spindle thread inside
 Seats and cone are renewable
 flanged

Equivalent to Vaihinger 68/1

Product group **760**

Type **68**

Sheet: 1

Revision: 0

Date:

08/2011

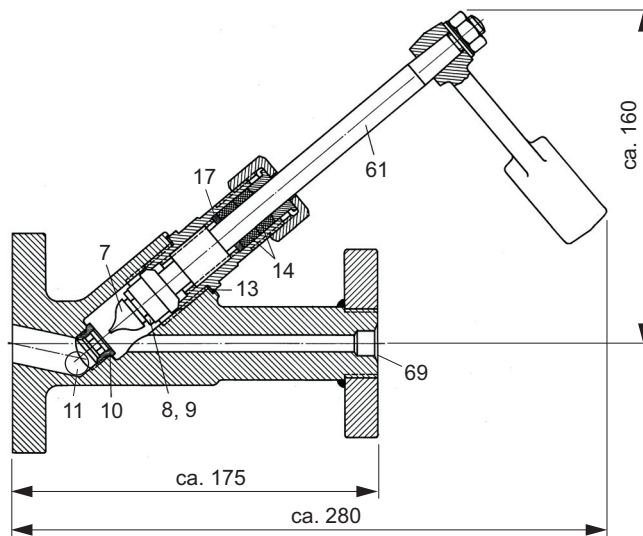

Field of Application

The gauge valve is to close the vessel against the level gauge. It is actuated by a quick closing lever. As a standard an automatic ball check is integrated. The process connection is manufactured acc. to customer's specification.

General Data

Valve pass: 8 mm
 Material
 - Housing, nipple, flange: CS/SS
 - Trim: SS
 other materials on request
 Orientation: horizontally, see Fig. orientation
 Ball check diff. pressure: >0,5 bar
 Process connection: DIN/ANSI acc. to cust. spec.
 Weight: ca. 5,0 kg

Design Data

Nominal pressure: CL 600
 Design temp./Design pressure: -10 ... +300 °C/82 bar

Orientation

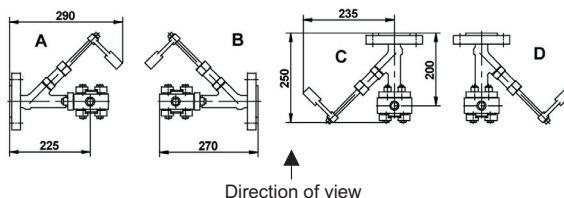

Measures in mm

Spare parts kit **BG681EKIT** consisting of:

Pos.	Denomination	Dimension	Material
61	Spindle	2840G53	SS
7	Cone	2811254	SS
8	Screw connect.	277154	SS
9	Semi-lunar ring	18202	SS
13	Sealing	D07603S35028	1.1003
14	Packing	0021001360GR	Graphit
17	Base ring	2586135	1.0501
10	Seat	2790b54	SS
11	Ball	D054011014	SS
69	Lens gasket	218238	1.0305

CS (= carbon steel) rsp. SS (= stainless steel type 316SS) are materials suitable for pressure vessels according to EN or ASME.

subject to alterations

Ordering no.

760.68001 - _ _ _ _ X X X

	X X X	See 700.VAR	Process connection
1	up to PN100 orientation A, B, C or D		Orientation
2	up to PN63 orientation A or B		



ING. ROLF HEUN
 Mess- Prüf- Regeltechnik GmbH

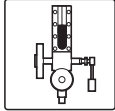

Illumination Transparent Sight Glass Level Gauges Even bright illumination Bulb, high light-performance und long lifetime	Product group 709	
	Type 0XXX	
	Sheet: 1/1	Revision: 1
	Date: 08/2011	

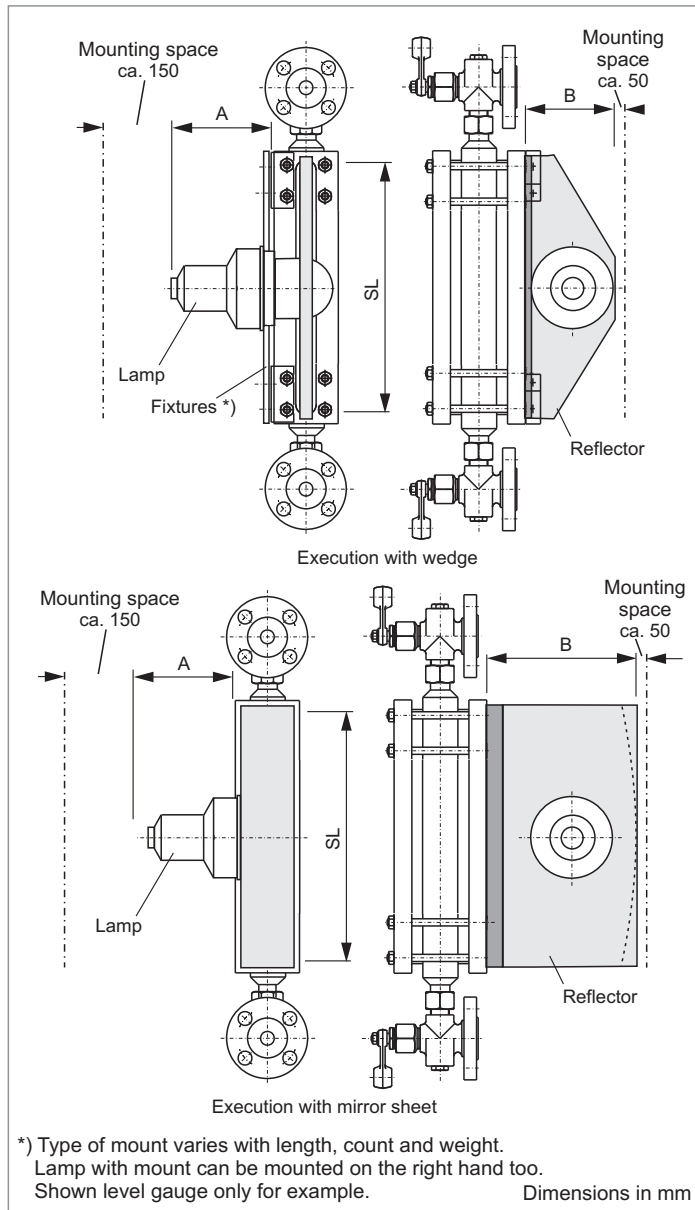

Field of Application

The illuminations are designed for illuminating sight windows according to DIN 7081 and mica sight windows. By variation segment length and number of segments as well as the optical power illumination can be adapted to most applications. Can be operated in hazardous area.

General Data

Material housing lamp: Alu
 Material reflector: Glass, Acryl-Glass, mirror sheet
 Dimensions
 - A: ca. 160
 - B: up to glass size 12 ca. 200
 from glass size 12 ca. 300
 Weight: 1,8 kg

Design Data

Ex-classification: II 2 GD Ex d (Ex de) IIC T2...T6
 Surface temperature: depends on temperature class and lamp power
 Ambient temperature: -50...+55 °C

Electrical Data

Power supply: 120/230 VAC
 Lamp power: max. 100 W
 Illustration: Halogen bulb
 Lamp holder: E27
 Ingress protection: IP 66

Certificates

EC-Type Examination Certificate: CESI 01 ATEX 028

Subject to alterations

Ordering no.

7 0 9 . 0 X X X A X X X X - X X X X - Sight length SL

Power supply	230 VAC	1	G Glass wedge *)	Reflector
	120 VAC	2		
Lamp power	100 W	P	S Mirror sheet	
	40 W	N	1 <=420 mm	
Approval	Standard	1	2 >420 mm	Sight glass type
	ATEX	2	R F Refraction	
Mat. housing	Aluminum	A	R G bi-color (Red-Green)	
			S T Standard	
			*) only for Standard	



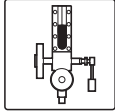

Sight glass level gauges

Frost protection
 Flat glasses
 Gaskets

Product group **700**

Type **-**

Sheet: 1 Revision: 0

Date: 08/2011

Frost protection

Material: PMMA

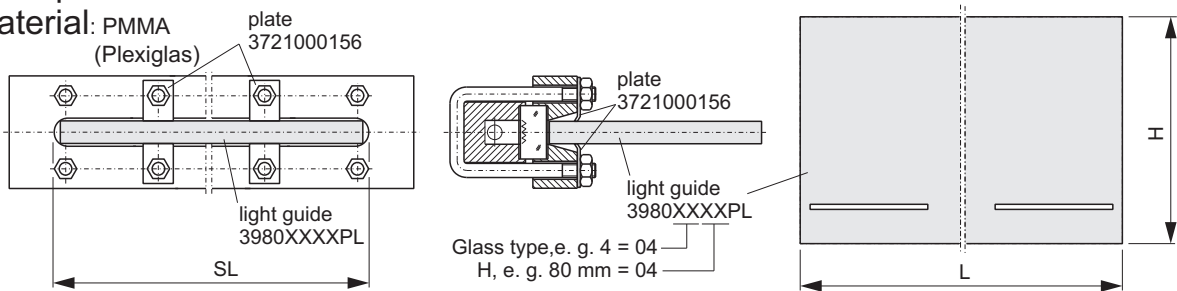

Glass type	00	1	2	3	4	5	6	7	8	9	10	11	12	13	14	15	16	17	18	19	20
L	72	92	117	142	167	197	227	257	297	317	347	377	407	437	477	507	537	577	607	637	677

H in mm covers temperature in °C below zero, standard heights: 80, 120, 180 und 220 mm recommended types

Flat glasses

acc.to DIN 7081

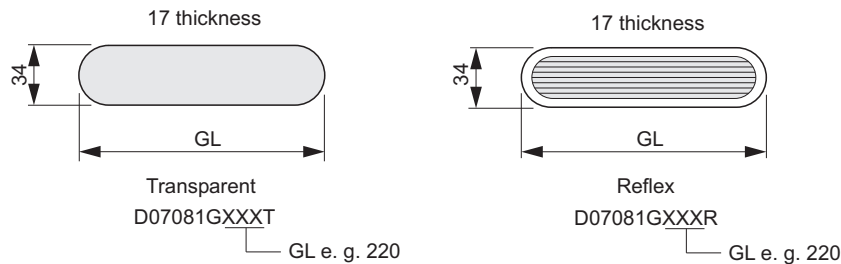

Glass type	0	1	2	3	4	5	6	7	8	9	10	11	12	13	14	15	16	17	18	19	20
GL	095	115	140	165	190	220	250	280	320	340	370	400	430	460	500	530	560	600	630	660	700

recommended types

Gaskets

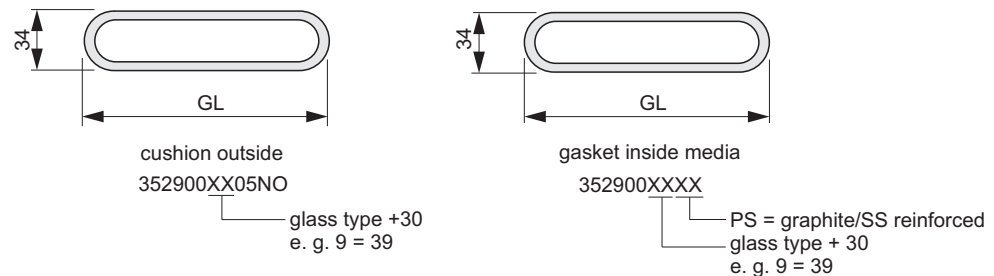

Measures in mm

Glass type	0	1	2	3	4	5	6	7	8	9	10	11	12	13	14	15	16	17	18	19	20
GL	95	115	140	165	190	220	250	280	320	340	370	400	430	460	500	530	560	600	630	660	700

recommended types

Subject to alterations



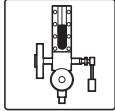

Sight glass level gauge Mica sheets Gaskets Mica packages Corrosion protection Pointer low water	Product group 700	
	Type -	
	Sheet: 1	Revision: 1
	Date: 08/2011	

Mica and gasket

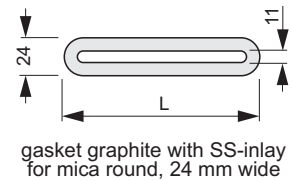
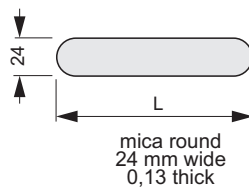
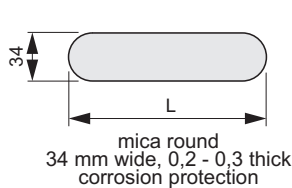

mica size	L	mica round 34 mm wide 0,2 - 0,3 mm	mica round 24 mm wide 0,13 mm	gasket graphite-SS 24 mm wide	mica package round 24 mm wide		
					0,9-1,0 mm dick	1,2 mm dick	1,7 mm dick
0	95	39890800GL	39897700GL	418D10200VG	39893700GL	39894700GL	39896700GL
1	115	39890801GL	39897701GL	418D10201VG	39893701GL	39894701GL	39896701GL
2	140	39890802GL	39897702GL	418D10202VG	39893702GL	39894702GL	39896702GL
3	165	39890803GL	39897703GL	418D10203VG	39893703GL	39894703GL	39896703GL
4	190	39890804GL	39897704GL	418D10204VG	39893704GL	39894704GL	39896704GL
5	220	39890805GL	39897705GL	418D10205VG	39893705GL	39894705GL	39896705GL
6	250	39890806GL	39897706GL	418D10206VG	39893706GL	39894706GL	39896706GL
7	280	39890807GL	39897707GL	418D10207VG	39893707GL	39894707GL	39896707GL
8	320	39890808GL	39897708GL	418D10208VG	39893708GL	39894708GL	39896708GL
9	340	39890809GL	39897709GL	418D10209VG	39893709GL	39894709GL	39896709GL
10	370	39890810GL	39897710GL	418D10210VG	39893710GL	39894710GL	39896710GL
11	400	39890811GL	39897711GL	418D10211VG	39893711GL	39894711GL	39896711GL
12	430	39890812GL	39897712GL	418D10212VG	39893712GL	39894712GL	39896712GL
13	460	39890813GL	39897713GL	418D10213VG	39893713GL	39894713GL	39896713GL
14	500	39890814GL	39897714GL	418D10214VG	39893714GL	39894714GL	39896714GL
15	530	39890815GL	39897715GL	418D10215VG	39893715GL	39894715GL	39896715GL

Mica packages P_{Design}

package thickness	P _{design} [bar]		
	80	120	150
0,9 - 1,0	X		
1,2		X	
1,7			X

For each mica window a mica package up to 1,7 mm thickness and a gasket for each package is needed.

Measures in mm

Corrosion protection

Corrosion protection for sight glasses from water side acc. to DIN 7081 above 243 °C 1 mica sheet is needed.

Pointer low water

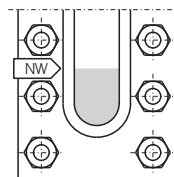

Form, size and inscription vary depending upon execution of the boiler level gauge

Subject to alterations



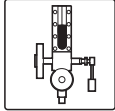

Sight glass level gauges Corrosion protection Scales Heating	Product group 700
	Type -
	Sheet: 1 Revision: 0
	Date: 08/2011

Corrosion protection with mica
 for transparent glasses acc. to DIN 7081

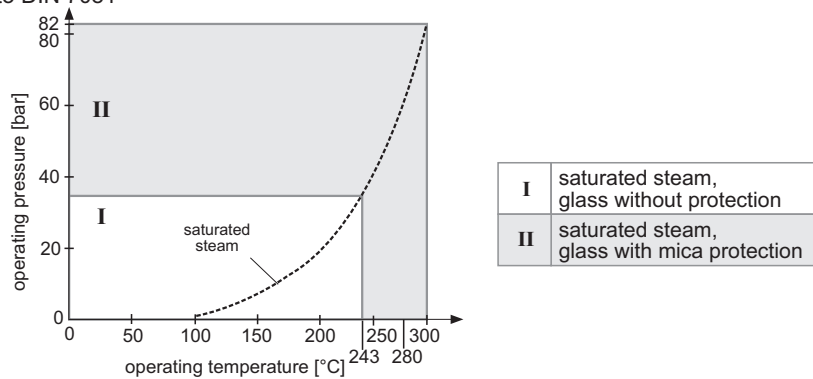

As corrosion protection you shall use 1 mica sheet with 0,2 to 0,3 mm thickness fitted to the inner side of a transparent glass acc. to DIN 7081 (marking 'water side' inward).

Corrosion protection and anti-adhesive

FEP-foil thickness 0,1 mm for transparent glasses acc. to DIN 7081 up to +200 °C, as corrosion protection or as anti-blocking means for media which are adherent to glass

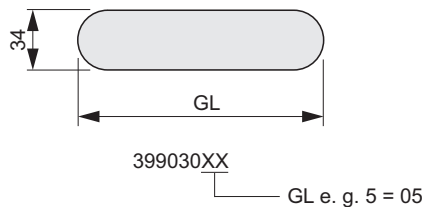

Measures in mm

Subject to alterations

Glass type	0	1	2	3	4	5	6	7	8	9	10	11	12	13	14	15	16	17	18	19	20
GL	95	115	140	165	190	220	250	280	320	340	370	400	430	460	500	530	560	600	630	660	700

Scales

Foil on Aluminum graduated in cm (up to 100 °C)
Foil on SS graduated in cm (up to 100 °C)
SS engraving graduated in cm
Pointer for water low indication, material Aluminum

Heating

Steam heating

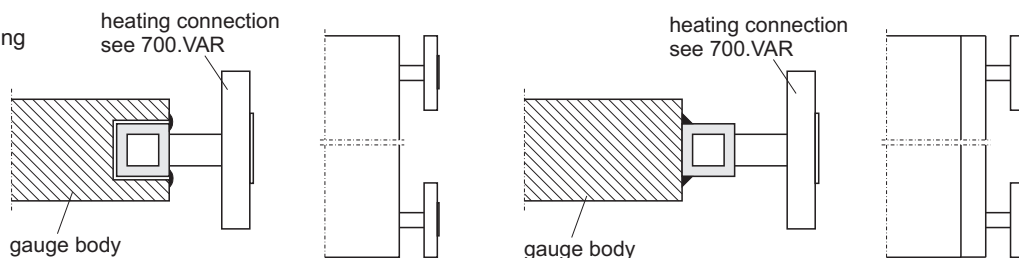

Orientation of the heating connection by customers specification. Electrical heating also possible.



Sight Glass Level Gauges

700.VAR

Model code

XXXXXX

DIN		ANSI		DIN		ANSI		
A	without facing	ST		F	tongue	RJ		Connection flange
B	female facing	LT		G	groove	LG		
C	DL-C			H	male	SG		
D	DL-D	RF		K	lens			
E	DL-E	RF sf						
A	DN10	1/4"		F	DN40	1 1/2"		Diameter
B	DN15	1/2"		G	DN50	2"		
C	DN20	3/4"		H	DN65	2 1/2"		
D	DN25	1"		I	DN80	3"		
E	DN32	1 1/4"		J	DN100	4"		
0	stud, welding end	F	PN160	R	PN6 (EN)			Nominal pressure, Process connection
1	PN100	G	PN250	S	PN10 (EN)			
2	PN160	H	PN320	T	male thread G			
3	PN250	I	PN400	U	male thread NPT			
4	PN320	J	150 lbs	V	PN16 (EN)			
5	PN400	K	300 lbs	W	PN25 (EN)			
9	custom design	L	600 lbs	X	stud, welding end			
A	PN6	M	900 lbs	Y	PN40 (EN)			
B	PN16	N	1500 lbs	Z	PN64 (EN)			
C	PN40	O	2500 lbs	b	PN10			
D	PN64	P	female thread G	c	PN25			
E	PN100	Q	female thread NPT					
X	same as vent							
Y	connection acc. to customer's specification							Vent
9	flange piece							
B	plug G1/2A							
C	plug 1/2" NPT							
D	vent G1/2A DN8 PN250							
E	vent 1/2" NPT DN8 PN250, socket							
F	vent 1/2" NPT DN8 PN250							
G	vent 1/2" NPT DN6 PN400							
I	vent 3/4" NPT DN8 PN250							
S	gate valve 1/2" NPT							
c	plug 3/4" NPT							
	number of glasses will be given separately							Glass type/ SL
0	glass type 0..9, A..J (10..19) DIN 7081; glass tube=0							
K	glass type 20 DIN 7081							
a	mica 190 mm							
b	mica 250 mm							
c	mica 290 mm							Glass protection/ temperature
d	mica 310 mm							
6	frost protection 60 mm (-60<=T<0 °C)							
8	frost protection 160 mm (-180<=T<-60 °C)							
9	frost protection custom design							
A	mica outside and inside (244<T<280 °C, only for H2O and transparent)							
I	mica outside (230<T<350 °C, not for H2O)							
Q	FEP-foil (0<T<200 °C, only for transparent)							
1	CS							Material chamber/ cover/ bolts
2	SS							
2	PN160							
4	1.4571/1.4571/A2-70 (T <400 °C)							
9	Special material							
A	1.4571/1.0460/A2-70							
L	316L/316L/193B8							
M	316L/A105/193B8							
R	A105/A105/193B7							
S	1.0460/1.0460/8.8 (T <300 °C)							
T	316Ti/316Ti/193B8							
U	A387Gr12/A387Gr12/193B7							
W	1.7335/1.7335/1.7709 (T <400 °C)							



Abbildung 0-6: Wasserdampf tabel, Sättigungszustand (unten)

Abbildung 0-7: Wasserdampf tabel, überhitzter Dampf (nächste Seite)

T 5.4 Wasserdampf tabel, Sättigungszustand (Druck tabel)¹

p bar	t °C	v' m ³ /kg	v'' m ³ /kg	h' kJ/kg	h'' kJ/kg	r kJ/kg	s' kJ/kg K	s'' kJ/kg K
0,0061	0	0,0010002	206,3	-0,04	2501,6	2501,6	-0,0002	9,1577
0,01	6,98	0,0010001	129,20	29,34	2514,4	2485,0	0,1060	8,9767
0,02	17,51	0,0010012	67,01	73,46	2533,6	2460,3	0,2607	8,7246
0,03	24,10	0,0010027	45,67	101,00	2545,6	2444,6	0,3544	8,5785
0,04	28,98	0,0010040	34,80	121,41	2554,5	2433,1	0,4225	8,4755
0,05	32,90	0,0010052	28,19	137,77	2561,6	2423,8	0,4763	8,3960
0,06	36,18	0,0010064	23,74	151,50	2567,5	2416,0	0,5209	8,3312
0,07	39,03	0,0010074	20,53	163,38	2572,6	2409,2	0,5591	8,2767
0,08	41,53	0,0010084	18,10	173,86	2577,1	2403,2	0,5925	8,2296
0,09	43,79	0,0010094	16,20	183,28	2581,1	2397,9	0,6224	8,1881
0,1	45,83	0,0010101	14,67	191,83	2584,8	2392,9	0,6493	8,1511
0,2	60,09	0,0010172	7,650	251,45	2609,9	2358,4	0,8321	7,9094
0,3	69,12	0,0010223	5,229	289,30	2625,4	2336,1	0,9441	7,7695
0,4	75,89	0,0010265	3,993	317,65	2636,9	2319,2	1,0261	7,6709
0,5	81,35	0,0010301	3,240	340,56	2646,0	2305,4	1,0912	7,5947
0,6	85,95	0,0010333	2,732	359,93	2653,6	2293,6	1,1454	7,5327
0,7	89,96	0,0010361	2,365	376,77	2660,1	2283,3	1,1921	7,4804
0,8	93,51	0,0010387	2,087	391,72	2665,8	2274,0	1,2330	7,4352
0,9	96,71	0,0010412	1,869	405,21	2670,9	2265,6	1,2696	7,3954
1,0	99,63	0,0010434	1,694	417,51	2675,4	2257,9	1,3027	7,3598
1,1	102,32	0,0010455	1,549	428,84	2679,6	2250,8	1,3330	7,3277
1,2	104,81	0,0010476	1,428	439,36	2683,4	2244,1	1,3609	7,2984
1,3	107,13	0,0010495	1,325	449,19	2687,0	2237,8	1,3868	7,2715
1,4	109,32	0,0010513	1,236	458,42	2690,3	2231,9	1,4109	7,2465
1,5	111,37	0,0010530	1,159	467,13	2693,4	2226,2	1,4336	7,2234
2,0	120,23	0,0010608	0,8854	504,70	2706,3	2201,6	1,5301	7,1268
3,0	133,54	0,0010735	0,6056	561,43	2724,7	2163,2	1,6716	6,9909
4,0	143,62	0,0010839	0,4622	604,67	2737,6	2133,0	1,7764	6,8943
6,0	158,84	0,0011009	0,3155	670,42	2755,5	2085,0	1,9308	6,7575
8,0	170,41	0,0011150	0,2403	720,94	2767,5	2046,5	2,0457	6,6594
10	179,88	0,0011274	0,1943	762,6	2776,2	2013,6	2,1382	6,5828
15	198,29	0,0011539	0,1317	844,7	2789,9	1945,2	2,3145	6,4406
20	212,37	0,0011766	0,0995	908,6	2797,2	1888,6	2,4469	6,3367
30	233,84	0,0012163	0,0666	1007,4	2802,3	1793,9	2,6455	6,1837
40	250,33	0,0012521	0,0498	1087,4	2800,3	1712,9	2,7965	6,0685
50	263,91	0,0012858	0,0394	1154,5	2794,2	1639,7	2,9206	5,9735
60	275,55	0,0013187	0,0324	1213,7	2785,0	1517,3	3,0273	5,8908
70	285,79	0,0013513	0,0274	1267,4	2773,5	1506,0	3,1219	5,8162
80	294,97	0,0013842	0,0235	1317,1	2759,9	1442,8	3,2076	5,7471
90	303,31	0,001418	0,0205	1363,7	2744,6	1380,9	3,2867	5,6820
100	310,96	0,001453	0,0180	1408,0	2727,7	1319,7	3,3605	5,6198
110	318,05	0,001489	0,0160	1450,6	2709,3	1258,7	3,4304	5,5595
120	324,65	0,001527	0,0143	1491,8	2689,2	1197,4	3,4972	5,5002
130	330,83	0,001567	0,0128	1532,0	2667,0	1135,0	3,5616	5,4408
140	336,64	0,001611	0,0115	1571,6	2642,4	1070,7	3,6242	5,3803
150	342,13	0,001658	0,0103	1611,0	2615,0	1004,0	3,6859	5,3178
160	347,34	0,001710	0,0093	1650,5	2584,9	934,3	3,7471	5,2531
180	356,96	0,001840	0,0075	1734,8	2513,9	779,1	3,8765	5,1128
200	365,70	0,002037	0,0059	1826,5	2418,4	591,9	4,0149	4,9412
210	369,78	0,002202	0,0050	1886,3	2347,6	461,3	4,1048	4,8223
220	373,69	0,002671	0,0037	2011,1	2195,6	184,5	4,2947	4,5799
221,2	374,15	0,00317		2107,4	0	0	4,429	

¹ Temperatur tabel s. T 6.1.